

M6238

Infrared Receiver Module
38kHz Carrier Frequency



Technical Data Sheet

Features:

- Photo detector and preamplifier in one package.
- Low voltage and low power consumption
- High photo sensitivity
- High protection ability against EMI
- Circular lens for improve the receive characteristics
- High immunity against ambient light
- Long reception range
- Pb free and RoHS compliant
- Compliance with EU REACH

Descriptions:

- The M6238 is miniaturized receiver for remote control systems. A PIN diode and a preamplifier are assembled on lead frame and molded into a black epoxy package which operates as an IR filter. The demodulated output signal can directly be decoded by a microprocessor.

Applications:

- AV equipment such as TV, VCR, DVD, CD, MD, etc.
- CATV set top boxes
- Multi-media Equipment
- Other devices using IR remote control

Device Selection Guide

Part No.	Carrier Frequency
M6238	38kHz

M6238

Infrared Receiver Module
38kHz Carrier Frequency

Technical Data Sheet

Package Dimension:

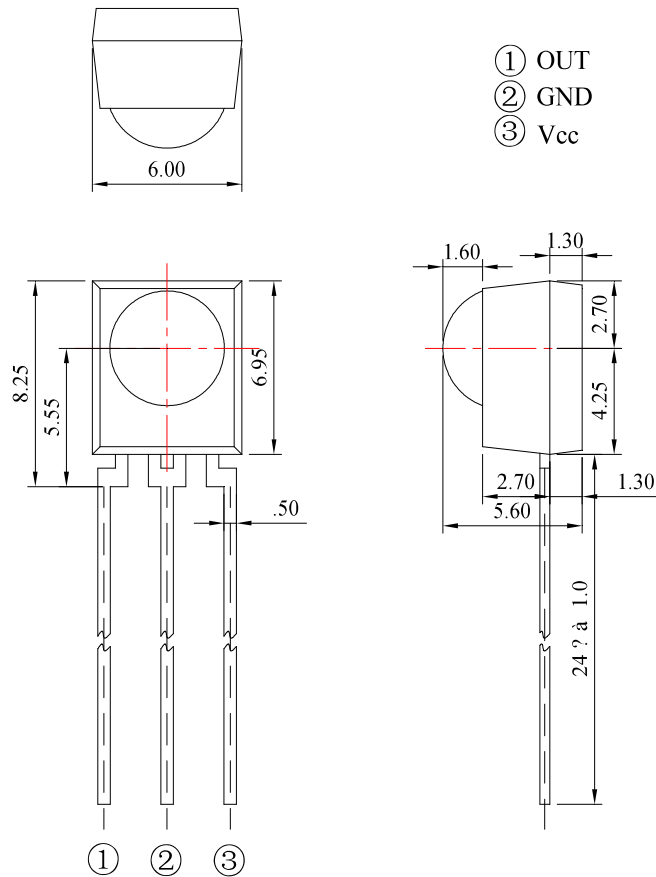

Notes:

1. All dimensions are in millimeters (inches).
2. Tolerance is ± 0.25 mm (.010") unless otherwise noted.
3. Protruded resin under flange is 1.00mm (.039") max.

M6238

Infrared Receiver Module
38kHz Carrier Frequency



Technical Data Sheet

Absolute Maximum Ratings at Ta=25°C

Item	Symbol	Value	Unit
Supply Voltage	Vcc	0~6.00	V
Operating Temperature	Topr	-40°C to +85°C	
Storage Temperature	Tstg	-40°C to +100°C	
Soldering Temperature	Tsol	260°C for 5 Seconds	

Notes:

- Derate linearly as shown in derating curve.
- Duty Factor = 10%, Frequency = 1 kHz.

Electrical Optical Characteristics at Ta=25°C

Parameters	Symbol	Min.	Typ.	Max.	Unit	Test condition
DC Supply Voltage	Vcc	---	3.00	---	V	---
Consumption Current	Icc	---	1.30	---	mA	No signal input
B.P.F Center Frequency	Fo	---	38	---	KHz	
Peak Wavelength	λ_p	---	940	---	nm	
Reception Distance	L0	14	---	---	m	At the ray axis*1
	L45	7	---	---		
Half Angle (Horizontal)	θ_h	---	45	---	deg	
Half Angle (Vertical)	θ_v	---	45	---		
High Level Pulse Width	TH	400	---	800	μ s	At the ray axis*2
Low Level Pulse Width	TL	400	---	800		
High Level Output Voltage	VH	2.70	---	---	V	
Low Level Output Voltage	VL	---	---	0.25		

M6238

Infrared Receiver Module
38kHz Carrier Frequency



Technical Data Sheet

Notes:

- a. $\theta_{1/2}$ is the off-axis angle at which the luminous intensity is half the axial luminous intensity.

Typical Electrical / Optical Characteristics Curves (25°C Ambient Temperature Unless Otherwise Noted)

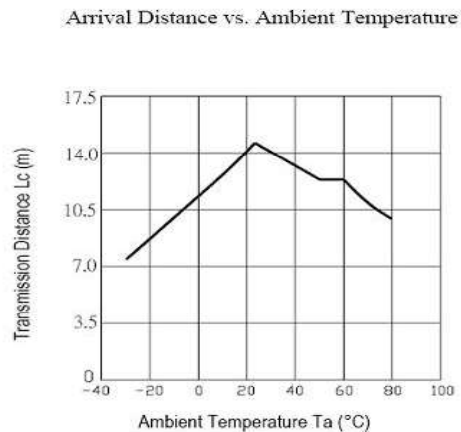
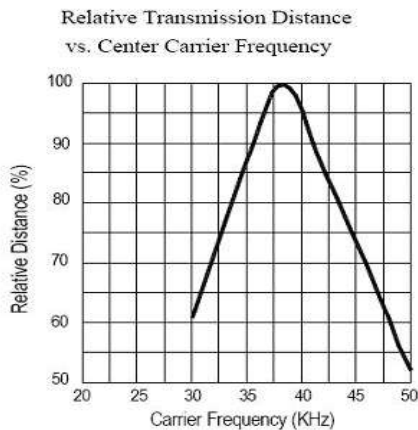
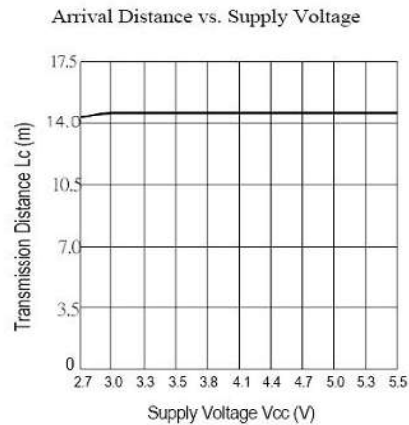
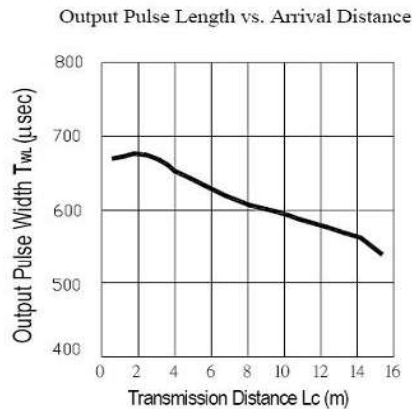
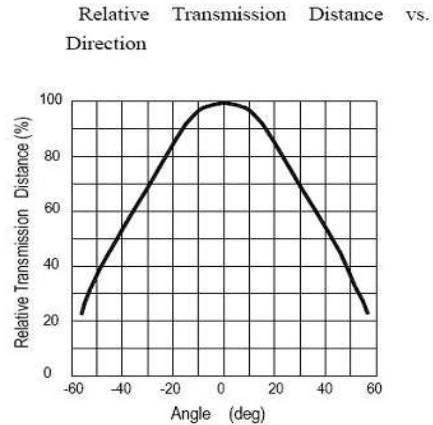
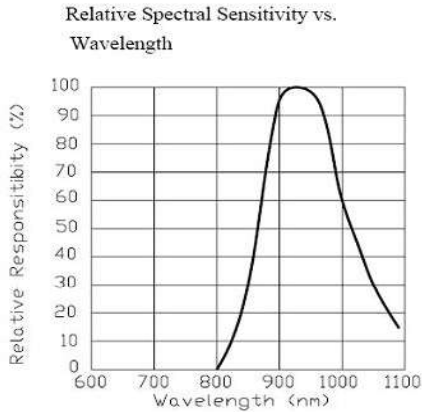

M6238

Infrared Receiver Module 38kHz Carrier Frequency



Technical Data Sheet

Test Method:

The specified electro-optical characteristic is satisfied under the following conditions at the controllable distance.

1.Measurement place.

A place that is nothing of extreme light reflected in the room.

2.External light.

Project the light of ordinary white fluorescent lamps which are not high frequency lamps and must be less than 10Lux at the module surface. ($E_e \leq 10\text{Lux}$)

3.Standard transmitter

A transmitter whose output is so adjusted as to $V_o=400\text{mVp-p}$ and the output wave form shown in Fig.-1.According to the measurement method shown in Fig.-2 the standard transmitter is specified. However, the infrared photodiode to be used for the transmitter should be $\lambda_p=940\text{nm}$, $\Delta\lambda=50\text{nm}$. Also, photodiode is used of PD516AD ($V_R=5\text{V}$). (Standard light / Light source temperature 2856°K).

4.Measuring system.

According to the measuring system shown in Fig.-3.

Fig.-1 Transmitter Wave Form

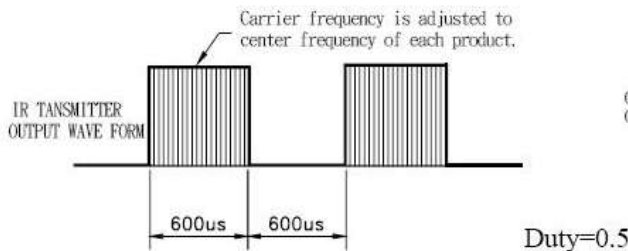

D.U.T output Pulse

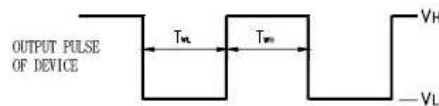

Fig.-2 Measuring Method

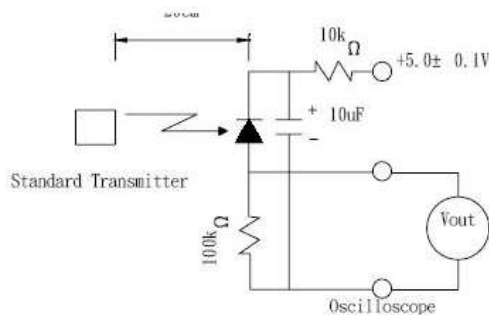
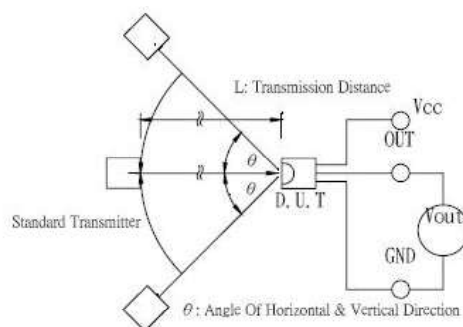

Fig.-3 Measuring System



M6238

Infrared Receiver Module
38kHz Carrier Frequency

Technical Data Sheet

Block Diagram:

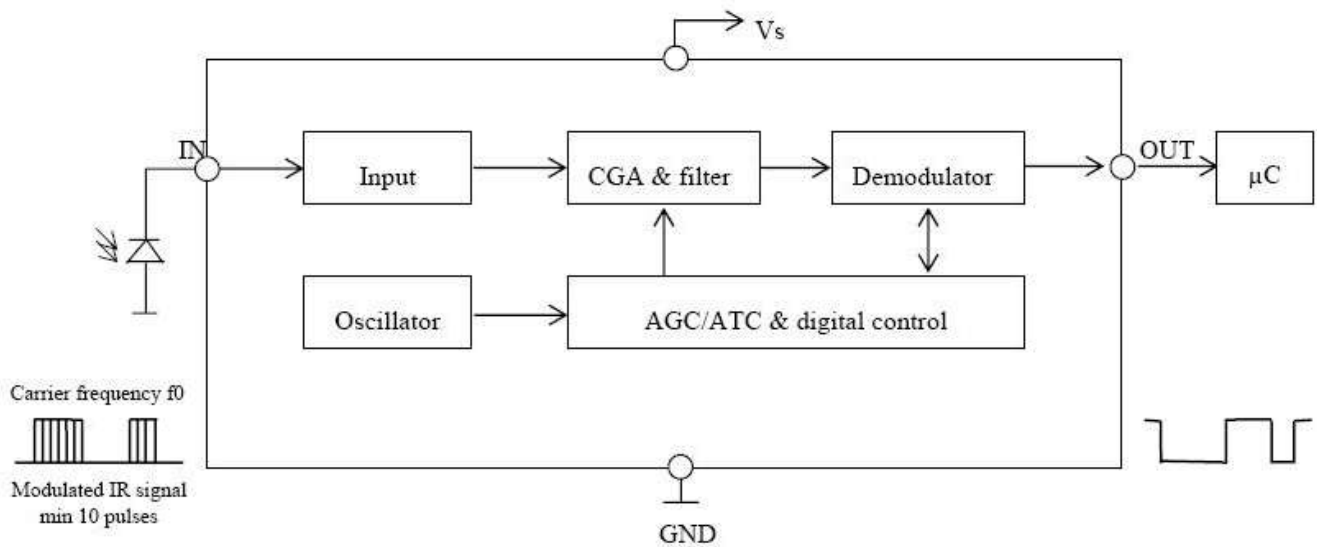

Applications Circuit:

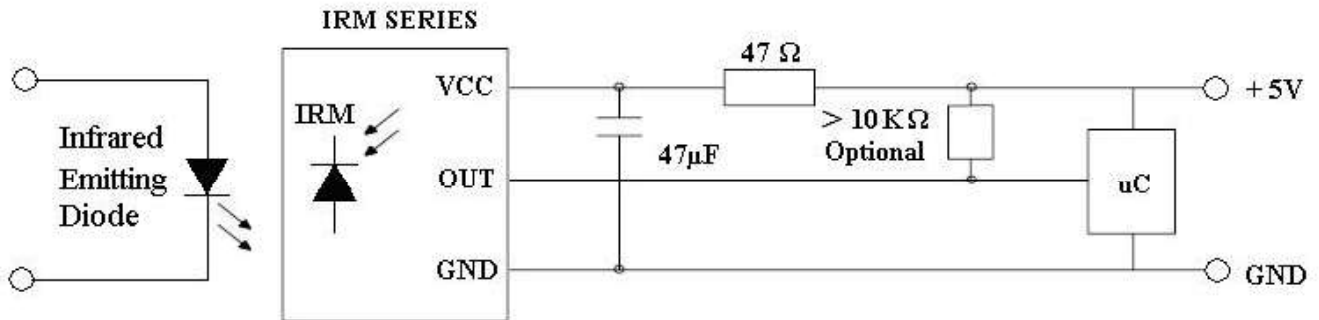

RC Filter should be connected closely between Vcc pin and GND pin.

M6238

Infrared Receiver Module
38kHz Carrier Frequency



Technical Data Sheet

Packing & Label Specifications:

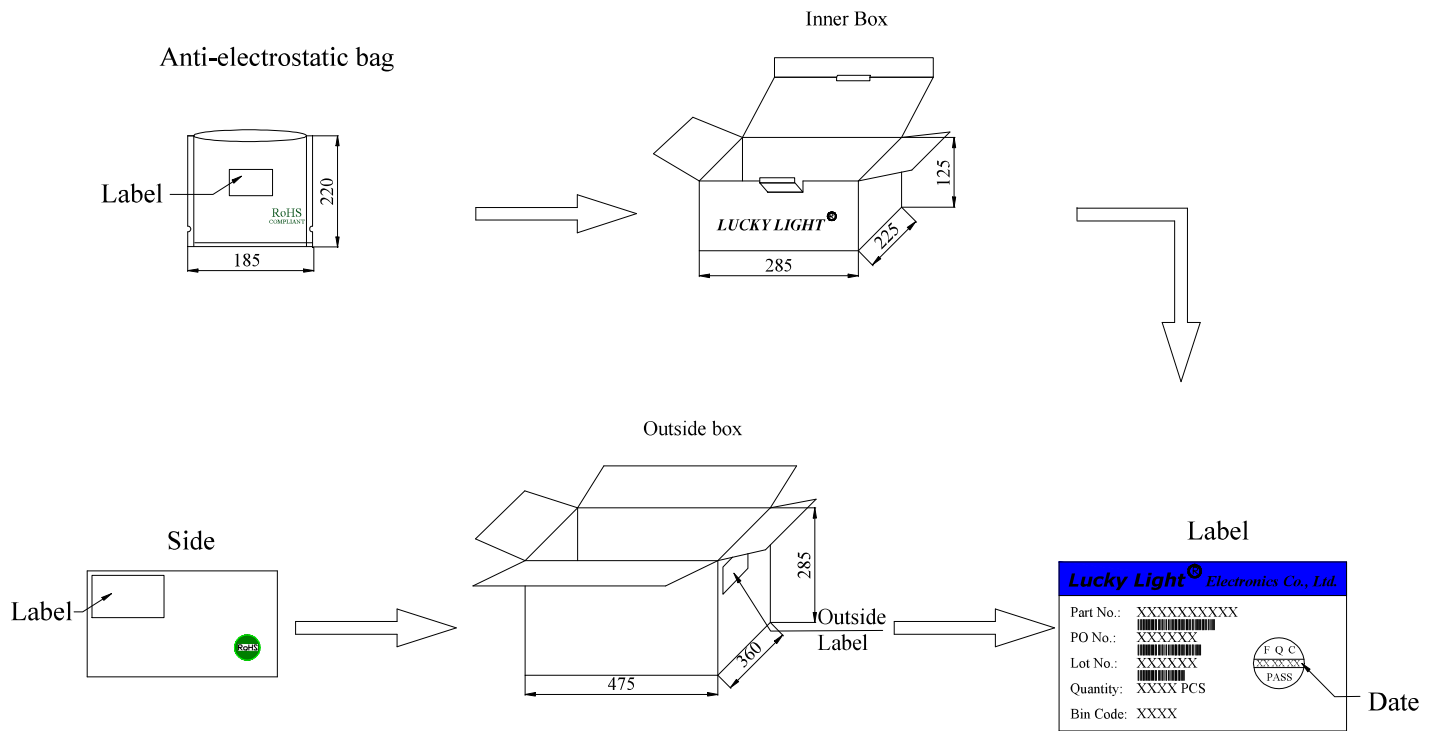

Packing Quantity:

- a. 250 PCS/bag.
- b. 5000~10000 PCS/Inner Box.
- c. 6 Inner Boxes/Outside Box.

Technical Data Sheet

CAUTIONS

1. General

- 1.1. Above specification may be changed without notice. LuckyLight will reserve authority on material change for above specification. When using this product, please observe the absolute maximum ratings and the instructions for use outlined in these specification sheets. LuckyLight assumes no responsibility for any damage resulting from use of the product which does not comply with the absolute maximum ratings and the instructions included in these specification sheets
- 1.2. DIP Type IR receiver modules can be mounted in any position. The leads may be bent, but the bend should not be less than 2mm from the bottom of the plastic package. During bending, force should not be transmitted from the leads to the package (e.g. by spreading the leads). If the device is mounted near heat generating components, the resulting increase in ambient temperature should not exceed the specified ratings.

2. Storage

- 2.1. The IR receiver modules should be used within a year
- 2.2. The devices are sensitive to damage due to moisture release if they are subjected to infrared reflow or a similar soldering process (e.g. wave soldering) without being properly dried. Be sure to observe the following storage conditions:
 - 2.2.1. Storage temperature 10 °C to 30 °C
 - 2.2.2. Storage humidity at 60 % RH maximum
- 2.3. The IR receiver modules used within 72hours after opening the package

3. Soldering

Protection against overheating is essential when a device is being soldered. It is recommended, where the design permits, that the length of the leads between the solder joint and the package be left as long as possible. The maximum permissible soldering temperature for plastic encapsulated devices is governed by the maximum permissible heat that may be applied to the plastic rather than by the maximum permissible junction temperature of the die.

M6238

Infrared Receiver Module

38kHz Carrier Frequency

LuckyLight

Technical Data Sheet

Recommended soldering conditions:

Soldering Iron		Wave Soldering	
Temperature	300°C Max.	Pre-heat	100°C Max.
Soldering Time	3 sec. Max. (one time only)	Pre-heat Time	60 sec. Max.
		Temperature	260°C Max.
		Soldering Time	5 sec. Max.