

AS-PDIC-L750-TR8

2.0x2.0mm, Ambient Light Sensor

With I²C Interface

Technical Data Sheet

Features:

- 10~16bit ADC resolution
- Specially coated photo diode with an optical response similar to human eyes
- High resolution (0.0033Lux/count)
- 50Hz/60Hz flicker noise and IR rejection
- Amplifier with adjustable gain (x1, x4, x8, x32, X96)
- Individual programmable low and high threshold for interrupt function
- Programmable integration time
- The product itself will remain within RoHS compliant version
- Compliance with EU REACH
- Compliance Halogen Free(Br < 900ppm, Cl < 900ppm, Br+Cl < 1500ppm)

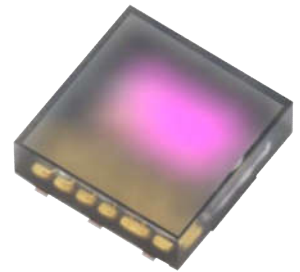

Descriptions:

- The AS-PDIC-L750-TR8 is a digital output ambient light with I²C interface and interrupt. It has a flexible and wide operating range for the ambient light sensor with a maximum resolution of 0.0033Lux/count and a maximum detectable illumination of 83000Lux. The AS-PDIC-L750-TR8 built-in an optical filter for IR rejection, and providing a spectrum which is close to the human eye's response. Dual-channel output (human eye and clear), so it has excellent light ratio under different light conditions.

Applications:

- Detection of ambient for controlling the backlight of TFT LCD display.
- Automatic residential and commercial lighting management.
- Automatic contrast enhancement for electronic signboard.
- Mobile phone, Smart phone, PDA, Tablet PC.

Part No.	Emitting Color	Lens Color
AS-PDIC-L750-TR8	Ambient Light Sensor	Black

AS-PDIC-L750-TR8

2.0x2.0mm, Ambient Light Sensor

With I²C Interface



Technical Data Sheet

Package Dimension:

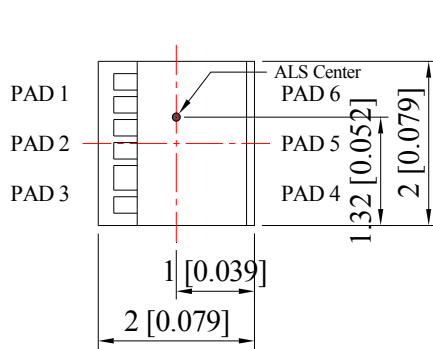

Top View

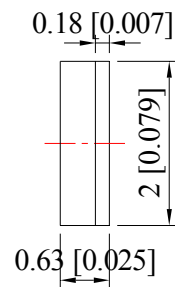

Side View

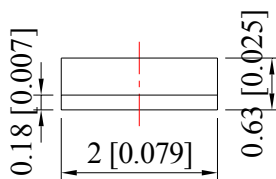

Side View

PAD Number	PAD Name
1	VDD
2	NC
3	GND
4	SCL
5	INT
6	SDA

Recommended Soldering Pad Dimensions

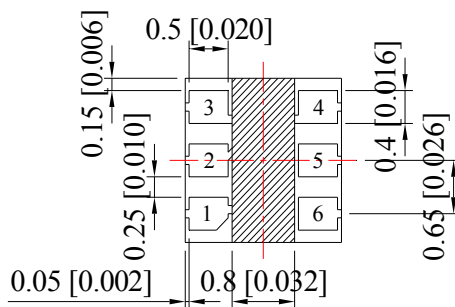

Bottom View

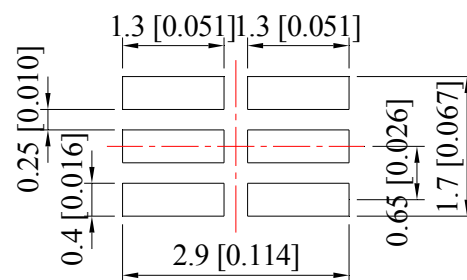

Unit: mm

Tolerance: ±0.10mm

Notes:

1. All dimensions are in millimeters (inches).
2. Tolerance is ± 0.25 mm (.010") unless otherwise noted.

AS-PDIC-L750-TR8

2.0x2.0mm, Ambient Light Sensor

With I²C Interface

Technical Data Sheet

Pad Description

Pin	I/O Type	Pin Name	Description
1	PWR	VDD	Power supply
2	NC	NC	No connection
3	GND	GND	Ground
4	I	SCL	I ² C serial clock line
5	O	INT	Interrupt pin
6	I/O	SDA	I ² C serial data line

Direction Denotation:

I/O Type	Dir.	I/O Type	Dir.
O	Output	GND	Ground
I	Input	GND	Input / Output
PWR	Power	NC	Not Connect

Block Diagram:

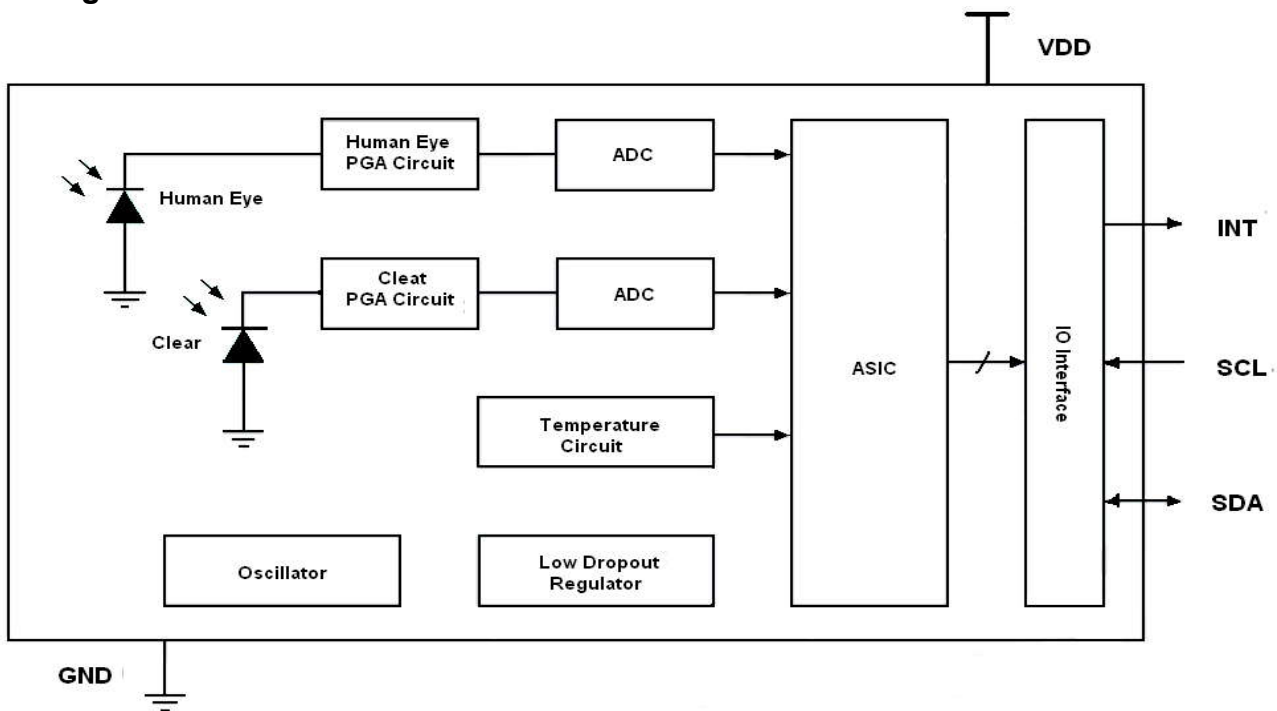

AS-PDIC-L750-TR8

2.0x2.0mm, Ambient Light Sensor

With I²C Interface



Technical Data Sheet

Absolute Maximum Ratings at Ta=25°C

Parameters	Symbol	Rating	Unit
Supply Voltage	V _{DD}	4.5	V
I ² C Bus Pin Voltage	SCL, SDA, INT	-0.2 to 4.5	V
I ² C Bus Pin Current	SCL, SDA, INT	10	mA
ESD Rating	Human Body Model	2	KV
Operating Temperature	T _{opr}	-40°C to +80°C	
Storage Temperature	T _{stg}	-45°C to +100°C	

Notes:

a. Exceeding these ratings could cause damage to the device. All voltages are with respect to ground. Currents are positive into, negative out of the specified terminal.

Recommended Operating Conditions

Parameter	Symbol	Min.	Typ.	Max.	Unit	Condition
Supply Voltage (Note a)	V _{DD}	2.4	---	3.6	V	---
I ² C Bus Pin Voltage	V _{Bus}	1.62	1.8	V _{DD}	V	V _{Bus} ≤ V _{DD}
Operating Temperature	T _{ope}	-40	---	+85	°C	---
I ² C Bus Input High Voltage (Note b)	V _{IH_SCL} ,	1.4	---	---	V	---
	V _{IH_SDA}					
I ² C Bus Input Low Voltage (Note b)	V _{IL_SCL} ,	---	---	0.5	V	---
	V _{IL_SDA}					
SDA Output Low Voltage	V _{OL_SDA}	0	---	0.4	V	3mA sinking current
INT Output Low Voltage	V _{OL_INT}	0	---	0.4	V	3mA sinking current

Notes:

a. The power supply need to make sure the V_{DD} slew rate at least 1.0V/ms. AS-PDIC-L750-TR8 have power on reset function. When V_{DD} drops below 2V under room temp, the IC will be reset automatically. Then power back up at the requirement slew rate, and write registers to the desired values.

b. The specs are defined under V_{DD}=3.3V, Ta=25°.

AS-PDIC-L750-TR8

2.0x2.0mm, Ambient Light Sensor

With I²C Interface



Technical Data Sheet

Electro-Optical Characteristics:

Parameter	Symbol	Min.	Typ.	Max.	Unit	Condition
Active Supply Current	I _{DD}	---	160	300	μA	E _v =0 lx Note 1
	I _{PD}	---	2.5	---	μA	Sleep mode E _v =0 lx I ² C inactive
Ambient Light Sensor						
ALS A/DC resolution	---	10	---	16	bit	---
Number of ADC integration time	ATIME	1	---	256	step	---
ALS Dark Output	CH0	0	1	5	counts	E _v =0 lx, ALS gain=x96, Tint=674ms
	CH1	0	1	5		
ALS detection output	CH0	1610	2300	2990	counts	E _v =100 lx, ALS gain=x32, Tint=170ms
	CH1	2170	3100	4030		
ALS detection resolution	---	---	---	0.0033	lx/count	ALS gain=x96, Tint=674ms
ALS maximum detection	---	---	---	83K	Lux	ALS gain=x1, Tint=5.5ms
ALS sensitivity peak wavelength	λ _{PALS}	---	550	---	nm	For channel 0

Notes:

a. V_{DD}=3.3V, T_a = 25 C, EN_ALS=1, ALSCONV=0x3F, PGA_ALS =0x04, WTIME=0x07.

AS-PDIC-L750-TR8

2.0x2.0mm, Ambient Light Sensor

With I²C Interface

Technical Data Sheet

I²C Write Format



I²C Block Write Format



I²C Read Format

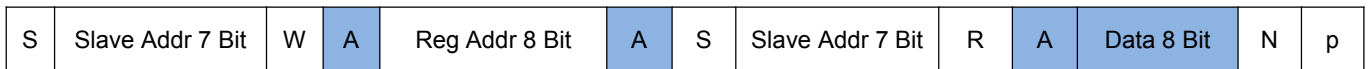

I²C Block Read Format

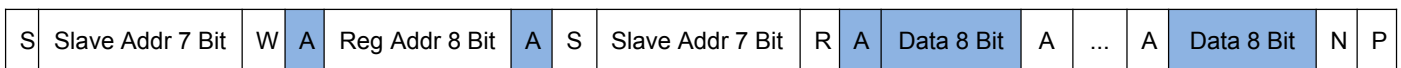

- Master to Slave S Start Condition, 1 Bit
- Slave to Master P Stop Condition, 1 Bit
- W Write, Set 0 for write, 1 Bit
- R Read, Set1 for read, 1 Bit
- A Acknowledge (ACK), Set 0, 1 Bit
- N Non acknowledge (NACK), Set 1, 1 Bit

I²C Slave Address and R/W bit

This address is seven bits long followed by an eighth bit which is a data direction bit (R/W). A '0' indicates a transmission (WRITE), a '1' indicates a request for data (READ). The slave address of this device is 0x38.

AS-PDIC-L750-TR8

2.0x2.0mm, Ambient Light Sensor

With I²C Interface



Technical Data Sheet

Register Set

The AS-DPIC-L750-TR8 is operated over the I²C bus with registers that contain configuration, status, and result information. All registers are 8 bits long.

Address	Name	Type	Default value	Description
0x00	SYSM_CTRL	RW	0x00	ALS operation mode control, waiting mode control, SW reset
0x01	INT_CTRL	RW	0x03	Interrupt pin control, interrupt persist control
0x02	INT_FLAG	RW	0x00	Interrupt flag, error flag, power on reset (POR) flag
0x03	WAIT_TIME	RW	0x00	Waiting time setting
0x04	ALS_GAIN	RW	0x00	ALS analog gain setting
0x05	ALS_TIME	RW	0x00	ALS integrated time setting
0x0B	PERSISTENCE	RW	0x11	ALS persistence setting
0x0C	ALS_THRES_LL	RW	0x00	ALS lower interrupt threshold - LSB
0x0D	ALS_THRES_LH	RW	0x00	ALS lower interrupt threshold - MSB
0x0E	ALS_THRES_HL	RW	0xFF	ALS higher interrupt threshold - LSB
0x0F	ALS_THRES_HH	RW	0xFF	ALS higher interrupt threshold - MSB
0x16	INT_SOURCE	RW	0x00	ALS interrupt source
0x17	ERROR_FLAG	RW	0x00	Error flag
0x1C	CH0_DATA_L	R	0x00	Channel 0 output data - LSB
0x1D	CH0_DATA_H	R	0x00	Channel 0 output data - MSB
0x1E	CH1_DATA_L	R	0x00	Channel 1 output data - LSB
0x1F	CH1_DATA_H	R	0x00	Channel 1 output data - MSB
0xBC	PNO_LB	R	0x14	Product number, Low Byte
0xBD	PNO_HB	R	0x16	Product number, High Byte

AS-PDIC-L750-TR8

2.0x2.0mm, Ambient Light Sensor

With I²C Interface



Technical Data Sheet

SYSM_CTRL

0x00	SYSM_CTRL, System Control (Default = 0x00)							
BIT	7	6	5	4	3	2	1	0
R/W	SWRST	EN_WAIT	0	0	0	0	0	EN_ALS

SWRST: Software reset. Reset all register to default value.

0: (default)

1: Reset will be triggered.

EN_WAIT: Waiting time will be inserted between two measurements.

0: Disable waiting function.

1: Enable waiting function.

EN_ALS: Enables ALS function.

0: Disable ALS function (default)

1: Enable ALS function

INT_CTRL

0x01	Interrupt Pin Control (Default = 0x03)							
BIT	7	6	5	4	3	2	1	0
R/W	0	0	0	ALS_SYNC	0	0	0	EN_AINT

ALS_SYNC: Measurement is pended when ALS interrupt is triggered. Until clear the interrupt then start the next measurement.

0: Disable pending ALS function (default).

1: Enable pending ALS function.

EN_AINT: The ALS interrupt (INT_ALS) flag can trigger the INT pin to low.

0: Disable INT_ALS effect INT pin.

1: Enable INT_ALS effect INT pin (default).

Technical Data Sheet**INT_FLAG**

0x02	INT_FLAG, System Control (Default = 0x00)							
BIT	7	6	5	4	3	2	1	0
R/W	INT_POR	DATA_FLAG	0	0	0	0	0	INT_ALS

INT_POR: Power-On-Reset Interrupt flag trigger the INT pin when the flag sets to one.

0: Write zero to clear the flag.

1: This bit will be set to one when it satisfy one of the following conditions:

- Power On
- VDD < 2.0V
- SWRST

DATA_FLAG: It shows if any data is invalid after completion of each conversion cycle. This bit is read-only.

0: data valid

1: data invalid

INT_ALS: ALS Interrupt flag. It correlation with CH0/1 data and ALS high/low threshold. Write zero to clear the flag.

0: ALS Interrupt not trigger or be cleared.

1: ALS Interrupt triggered.

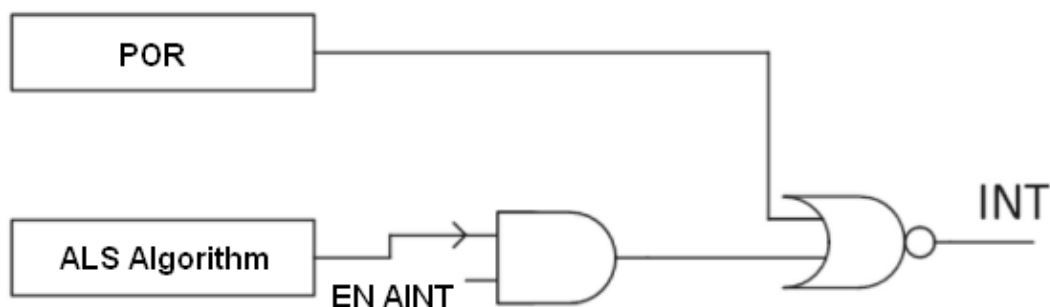
Interrupt Behavior:

Technical Data Sheet

ALS Interrupt Algorithm

Correlative register:

- The ALS Interrupt (**INT_ALS**, register 0x02, bit 0).
- The ALS Persistence (**PRS_ALS** register 0x0B, bit 0 to bit 3),
- The ALS Data (**CH0_DATA** and **CH1_DATA**, register 0x1C to 0x1F);
- The ALS Low Threshold (**ALS THRES L**, register 0x0C to 0x0D),
- The ALS High Threshold (**ALS THRES H**, register 0x0E to 0x0F).

INT_ALS triggered condition:

1. Rule of active interrupt: **DATA > ALS_THRES_H** or **DATA < ALS_THRES_L**.
2. If the **DATA** meets the rule, the **interrupt** count increases one.
If the **DATA** fails in the rule, the **interrupt** count will be clear.
3. When the **interrupt** count equal to **PRS_ALS** setting, **INT_ALS** will be triggered and reset the interrupt counter.
4. If **PRS_ALS** is set to zero, **threshold** will be ignored and **DATA** will meets the active interrupt rule forcibly.

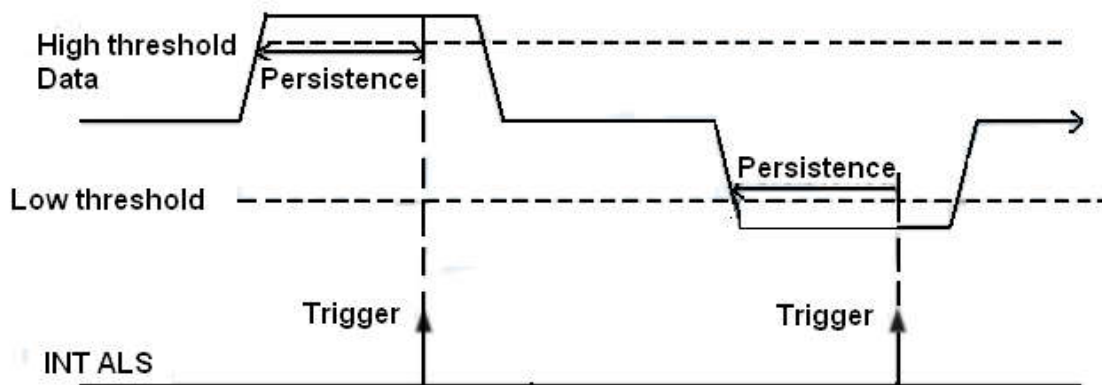

WAIT_TIME

0x03	WAIT_TIME, waiting time (Default = 0x00)							
BIT	7	6	5	4	3	2	1	0
R/W	WTIME							

WTIME: This register controls the time unit of waiting state which is inserted between any two measurements. It is 5ms per time unit.

0x00: 1 time unit.

0x01: 2 time units

AS-PDIC-L750-TR8

2.0x2.0mm, Ambient Light Sensor

With I²C Interface



Technical Data Sheet

.....

0xFF: 256 time units

ALS_GAIN

0x04	ALS_GAIN, ALS analog gain (Default = 0x00)							
BIT	7	6	5	4	3	2	1	0
R/W	0	0	0	0	0	PGA_ALS		

PGA_ALS: ALS sensing gain.

0x0: x1 (default)

0x1: x4

0x2: x8

0x3: x32

0x4: x96

0x5, 0x6, 0x7: NA

ALS_TIME

0x05	ALS_TIME, ALS integrated time (Default = 0x00)							
BIT	7	6	5	4	3	2	1	0
R/W	ALSCONV							

ALSCONV: This register controls the integrated time of AD converter at ALS mode (T_{ALS}), and the resolution of output data (CH0_DATA, CH1_DATA).

0x00: The maximum count of **output data is** 1023, $T_{ALS} = 5.513\text{ms}$ (default)

0x01: The maximum count of **output data is** 2047, $T_{ALS} = 8.138\text{ms}$

.....

0xff: The maximum count of **output data is** 65535, $T_{ALS} = 674.888\text{ms}$

The maximum count of **output data is** minimum of $[1024 \times (\text{ALSCONV} + 1) - 1, 65535]$.

The conversion time of ALS function (T_{ALS}) is decided by **ALSCONV**.

$T_{ALS} = 2.888 + 2.625 \times (\text{ALSCONV} + 1)$ (ms)

Technical Data Sheet**PERSISTENCE**

0x0B	PERSISTENCE, ALS persistence setting (Default = 0x11)							
BIT	7	6	5	4	3	2	1	0
R/W	0			1	PRS_ALS			

PRS_ALS: This register sets the numbers of similar consecutive ALS interrupt events before the interrupt pin is triggered.

0x0: Every ALS conversion is done.

0x1: 1 ALS interrupt event is asserted.

.....

0xf: 15 consecutive ALS interrupt events are asserted.

ALS_THRES_L

0x0C 0x0D	ALS_THRES_L, ALS low interrupt threshold (Default = 0x0000)							
BIT	7	6	5	4	3	2	1	0
R/W	ALS_THRE_LL							
R/W	ALS_THRE_LH							

This register sets the lower threshold value of ALS interrupt. The interrupt algorithm compares the selected ALS data and ALS threshold value.

ALS_THRE_LL: ALS lower interrupt threshold value, LSB. (Reg. 0x0C)

ALS_THRE_LH: ALS lower interrupt threshold value, MSB. (Reg. 0x0D)

ALS_THRES_H

0x0E 0x0F	ALS_THRES_H, ALS high interrupt threshold (Default = 0xFFFF)							
BIT	7	6	6	4	3	2	1	0
R/W	ALS_THRE_HL							
R/W	ALS_THRE_HH							

Technical Data Sheet

This register sets the high threshold value of ALS interrupt. The interrupt algorithm compares the selected ALS data and ALS threshold value.

ALS_THRE_HL: ALS high interrupt threshold value, LSB. (Reg. 0x0E)

ALS_THRE_HH: ALS high interrupt threshold value, MSB. (Reg. 0x0F)

INT_SOURCE

0x16	INT_SOURCE, ALS interrupt source (Default = 0x00)							
BIT	7	6	5	4	3	2	1	0
R/W	0	0	0	0	0	0	0	INT_SRC

INT_SRC: This register sets to select the ALS data for the ALS Interrupt algorithm.

0x0: Select CH0_DATA.

0x1: Select CH1 DATA.

ERROR_FLAG

0x17	ERROR_FLAG, Error flag status							
BIT	7	6	5	4	3	2	1	0
R/W	0	0	0	0	0	0	ERR_CH1	ERR_CH0

This register indicates the ALS data status. If the ALS data is outside of measurable range, the corresponding error flag (ERR_CH0, ERR_CH1) will set to one. That also means the data is invalid.

CH0_DATA

0x1C 0x1D	CH0_DATA, Channel 0 output data.							
BIT	7	6	5	4	3	2	1	0
R/W	CH0_DATA_L							
R/W	CH0_DATA_H							

Technical Data Sheet

The channel 0 result of ALS sensor is written into CH0_DATA when ALS conversion is done.

For insuring the data in the register comes the same measurement, the high byte data will be latched when the low byte data has been accessed until the high byte data has be read.

CH1_DATA

0x1E	CH1_DATA, Channel 1 output data.							
0x1F								
BIT	7	6	5	4	3	2	1	0
R/W	CH1_DATA_L							
R/W	CH1_DATA_H							

The channel 1 result of ALS sensor is written into CH1_DATA when ALS conversion is done.

For insuring the data in the register comes the same measurement, the high byte data will be latched when the low byte data has been accessed until the high byte data has be read.

I²C Interface Timing Characteristics

This section will describe the protocol of the I²C bus. For more details and timing diagrams please refer to the I2C specification.

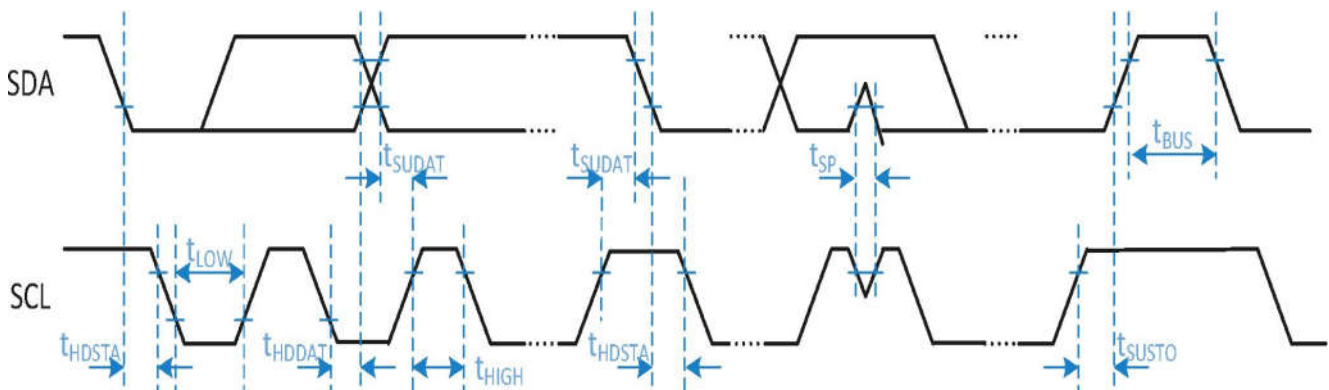

AS-PDIC-L750-TR8

2.0x2.0mm, Ambient Light Sensor

With I²C Interface



Technical Data Sheet

Parameter (*)	Symbol	I ² C Standard Mode		I ² C Fast Mode		Unit
		Min.	Max.	Min.	Max.	
SCL clock frequency	f _{SCL}	0	100	0	400	kHz
Bus free time between STOP condition and START condition	t _{BUS}	4.7	---	1.3	---	μs
LOW period of the SCL clock	t _{LOW}	4.7	---	1.3	---	μs
HIGH period of the SCL clock	t _{HIGH}	4	---	0.6	---	μs
Hold time (repeated) START condition	t _{HDSTA}	4	---	0.6	---	μs
Set-up time (repeated) START condition	t _{SUSTA}	4.7	---	0.6	---	μs
Set-up time for STOP condition	t _{SUSTO}	4	---	0.6	---	μs
Data hold time	t _{HDDAT}	0	3.45	0	0.9	μs
Data set-up time	t _{SUDAT}	250	---	100	---	μs
Rise time of both SDA and SCL signals	t _(r)	---	300	---	300	μs
Fall time of both SDA and SCL signals	t _(f)	---	1000	---	300	μs

(*) All specifications are at V_{bus} = 3.3V, T_{opr}=25°C, unless otherwise noted. Specified by design and characterization; not production tested.

Technical Data Sheet

Basic Operation Flow Chart

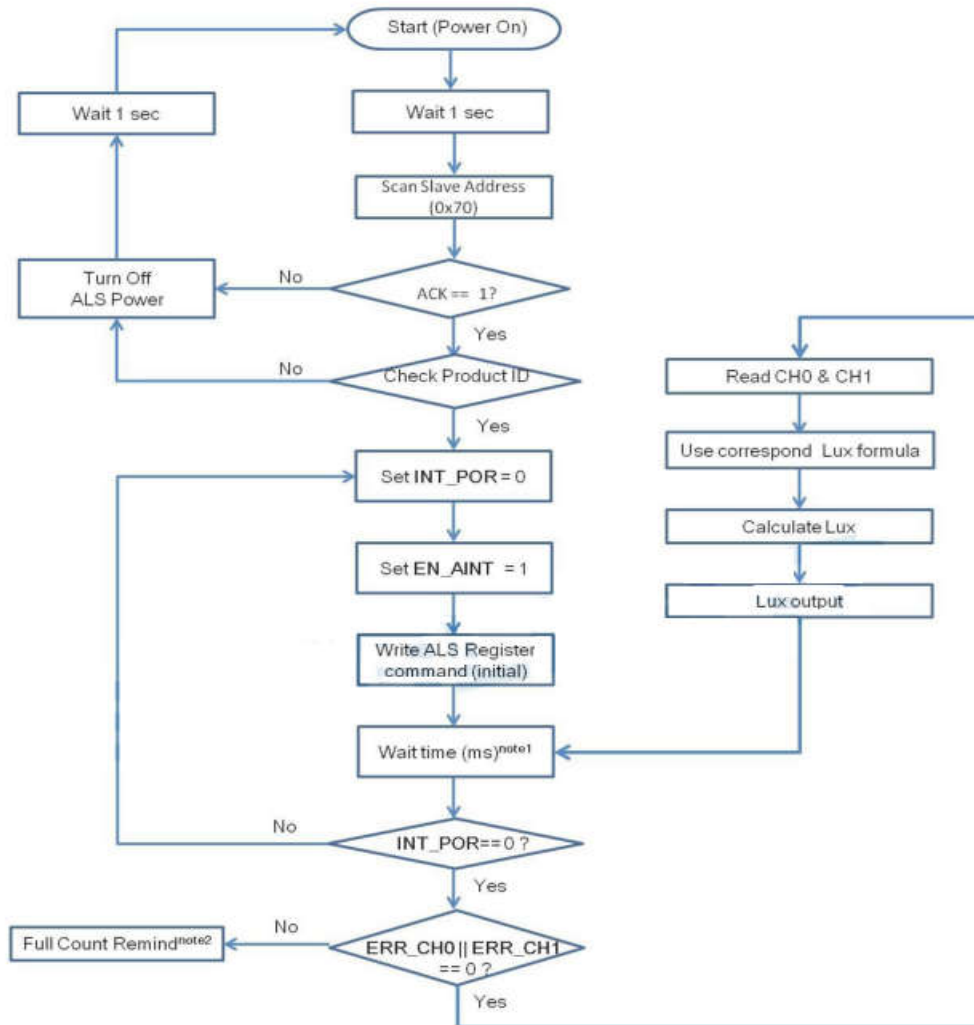

Notes:

1. The wait time need to be longer than WAIT_TIME + ALS_TIME (ms).
2. ERR CH0 || ERR CH1 =1 means ALS data is outside of measurable range.

Next steps can be decided by costumer, such as:

- Ignore the reminder and continue reading CH0 & CH1.
- Send an error message to MCU and wait for next command.
- Other error handling actions.

Technical Data Sheet**Lux Calculating**

User could calculate lux value by using the following equation (for white LED)

- If $CH0/CH1 < 0.42$, $Lux = (CHOI PGA_ALS) * [64 / (ALSCONV + 1)] * K1$
- If $0.42 < CH0/CH1 < 0.61$, $Lux = (CHOI PGA_ALS) * [64 / (ALSCONV + 1)] * K2$
- If $CH0/CH1 > 0.61$, $Lux = (CHOI PGA_ALS) * [64 / (ALSCONV + 1)] * K3$

Ex:

Register setting : **ALSCONV = 0x3F**; **PGA_ALS = 0x03**, **CHO/CH1=0.83**

$$Lux = (CHO / 32) * [64 / (63 + 1)] * 1.58$$

Notes:

1. Recommend calibrate value: **K1 = 0.41**, **K2=0.57**, **K3 =1.58**
2. The values for **K1**, **K2** and **K3** shown above are only valid for the sensor component. If the sensor is placed behind an optical system (e.g. lens, cover panel etc.) the values above might not be suitable for a lux calculation. In such case the values for **K1**, **K2** and **K3** must be determined in the application by using a luxmeter and the sensor readings.

Supply Voltage Drops

Upon power-up, please ensure the slew rate of VDD greater than 1.0V/ms. After power-up, the supply voltage shall NOT drop below 2.0V. Once it happens, please switch off the power, wait more than 1 second, and then power on the device again.

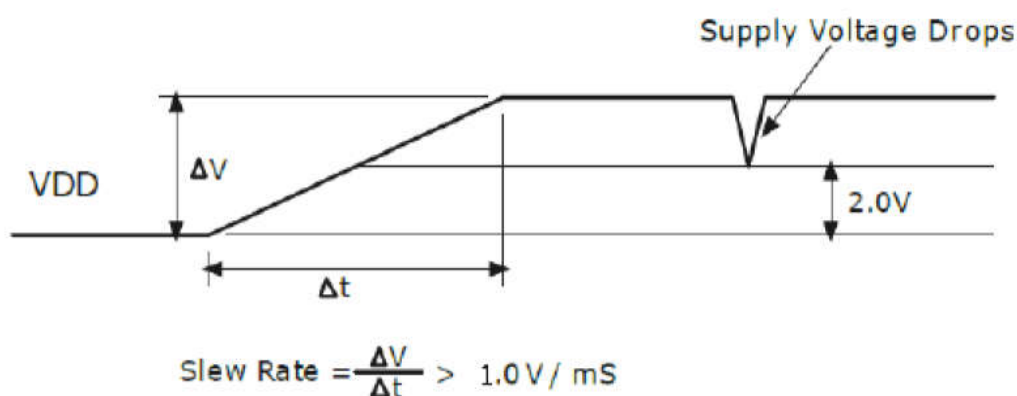

AS-PDIC-L750-TR8

2.0x2.0mm, Ambient Light Sensor
With I²C Interface



Technical Data Sheet

Note:

I²C Bus Clear

In the unlikely event where the clock (SCL) is stuck LOW, the preferential procedure is to reset the bus using the HW reset signal if your I²C devices have HW reset inputs. If the I²C devices do not have HW reset inputs, cycle power to the devices to activate the mandatory Internal Power-On Reset (POR) circuit.

If the data line (SDA) is stuck LOW, the master should send nine clock pulses. The device that held the bus LOW should release it sometime within those nine clocks.

I²C General Call Software Reset

Following a General Call, (0000 0000), sending 0000 0110 (06h) as the second byte causes software reset. This feature is optional and not all devices will respond to this command. On receiving this 2-byte sequence, all devices designed to respond to the general call address will reset and take in the programmable part of their address.

Precautions have to be taken to ensure that a device is not pulling down the SDA or SCL line after applying the supply voltage, since these low levels would block the bus.

Typical Application Circuit

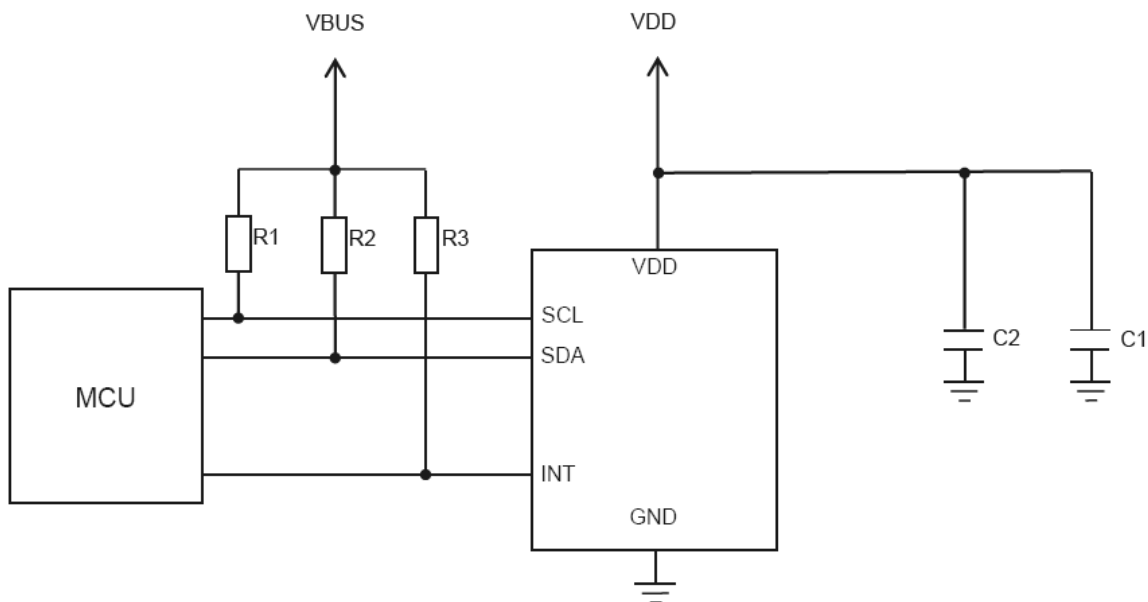

AS-PDIC-L750-TR8

Technical Data Sheet

The capacitors (C1, C2) are required for sensor power supply. The capacitors should be placed as close as possible to the device. The high frequency AC noises can be shunted to the ground by the capacitors. The transient current caused by digital circuit switching also can be handled by the capacitors. A typical value 0.1 / 1 μ F can be used.

The pull-up resistors (R1, R2) are required for I2C communication. At fast speed mode (400kHz/s) and VBUS = 3V, 1.0k Ω resistors can be used. The pull-up resistor (R3) is also required for the interrupt, a typical value between 10 k Ω and 100 k Ω can be used.

Typical Electrical / Optical Characteristics Curves (25°C Ambient Temperature Unless Otherwise Noted)

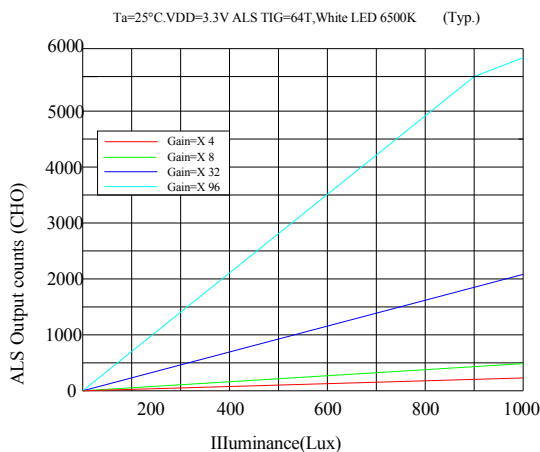

Fig.1 ALS output data VS. ALS Gain (For CH0)

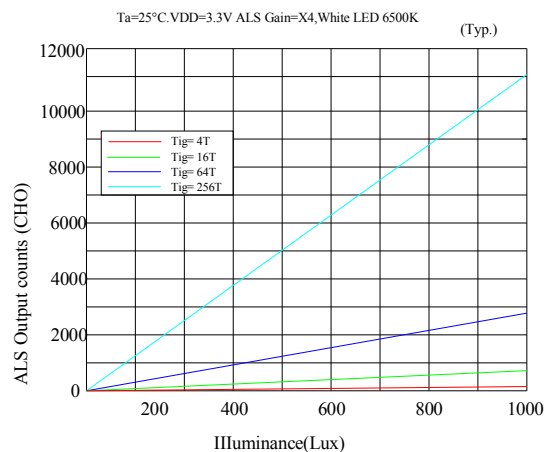

Fig.2 ALS output data VS. ADC Tig (For CH0)

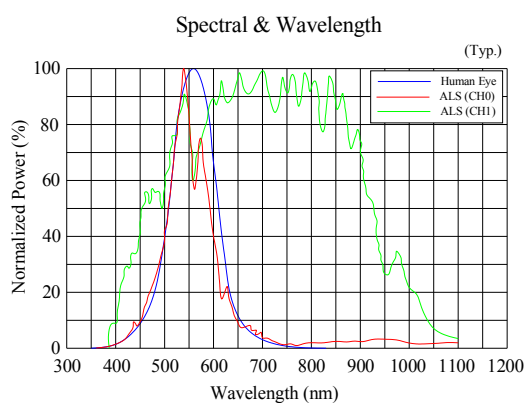

Fig.3 Spectral vs. Wavelength (For CH0)

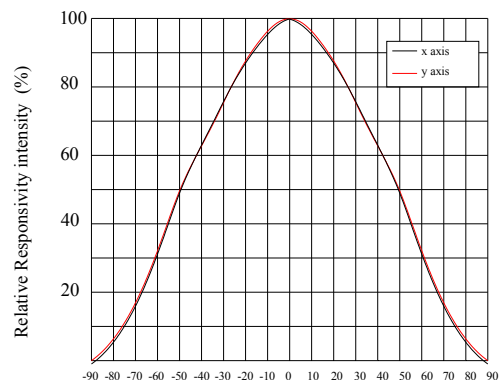

Fig.4 ALS view angle (For CH0)

AS-PDIC-L750-TR8

2.0x2.0mm, Ambient Light Sensor

With I²C Interface



Technical Data Sheet

Reel Dimensions:

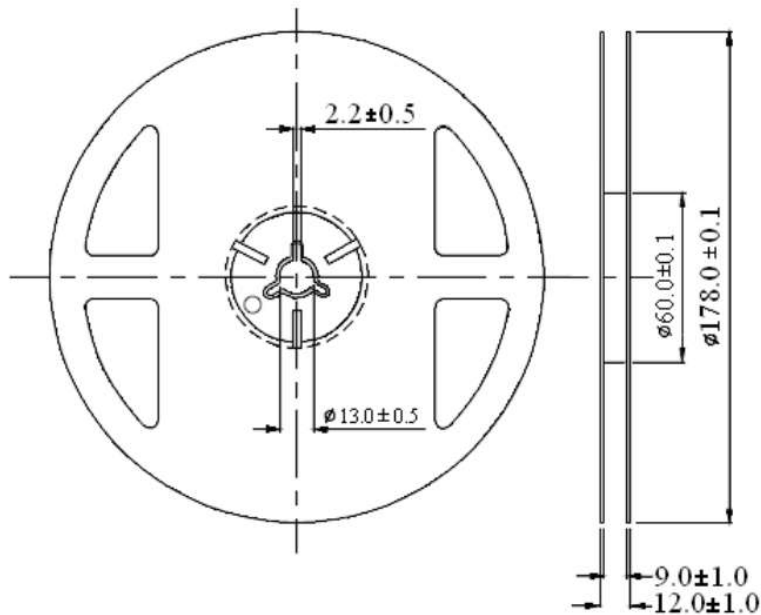

Unit: mm
Tolerance: ± 0.25mm

Carrier Tape Dimensions:

Loaded quantity 2000 pcs per reel.

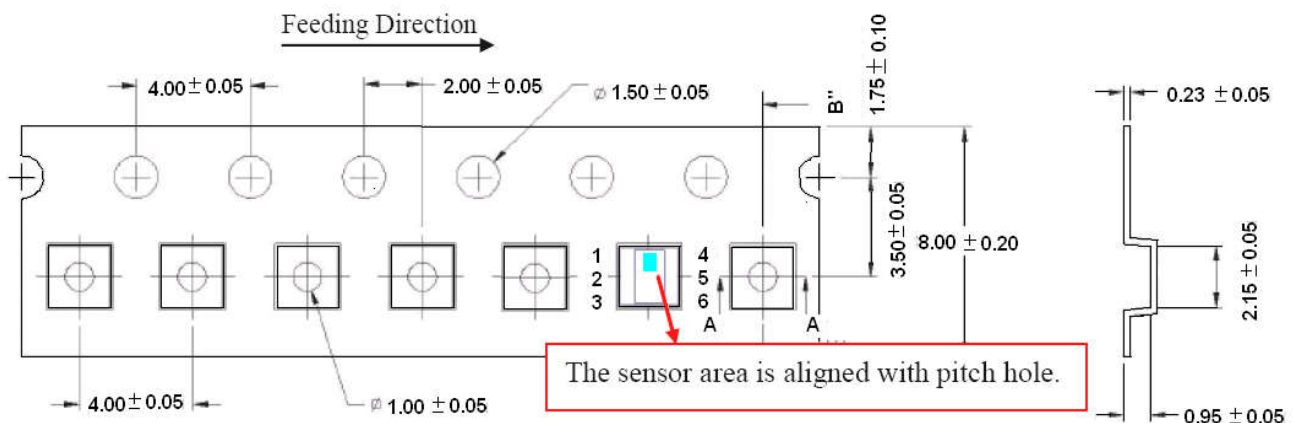

AS-PDIC-L750-TR8

2.0x2.0mm, Ambient Light Sensor

With I²C Interface



Technical Data Sheet

Packing & Label Specifications:

Moisture Resistant Packaging:

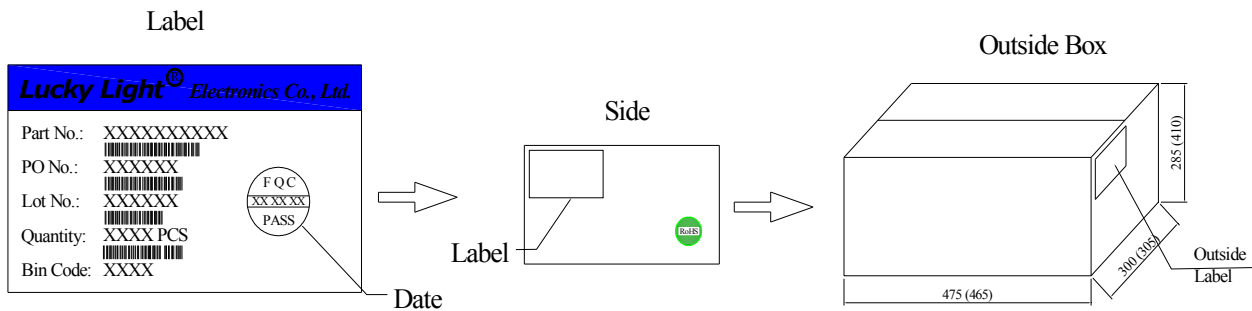
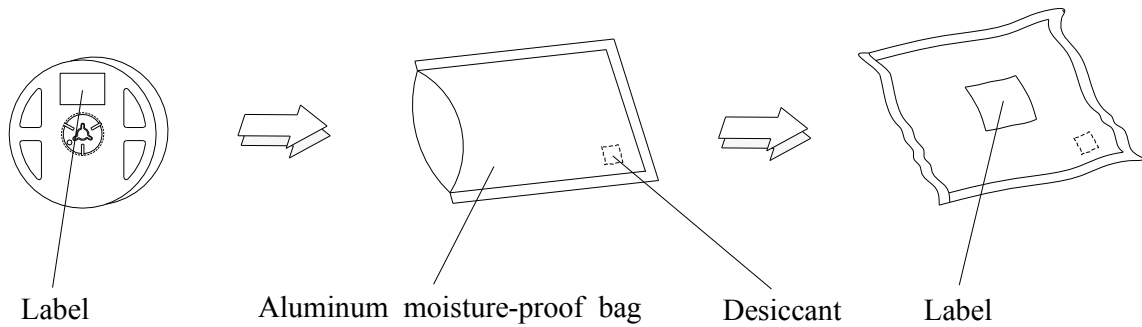

Technical Data Sheet

CAUTIONS**1. Handling Precautions:**

- 1.1. Handle the component along the side surfaces by using forceps or appropriate tools.
- 1.2. Do not directly touch or handle the silicone lens surface. It may damage the internal circuitry.
- 1.3. Do not stack together assembled PCBs containing exposed ALS (Ambient Light Sensor). Impact may scratch the silicone lens or damage the internal circuitry.

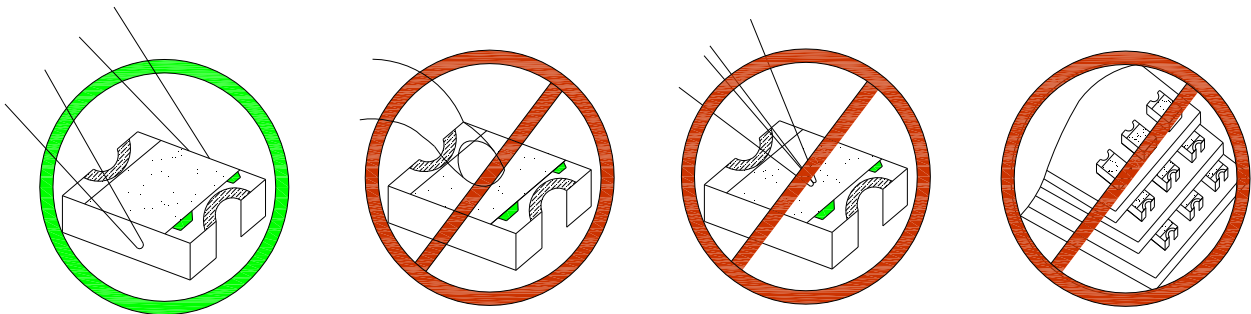

Compare to epoxy encapsulant that is hard and brittle, silicone is softer and flexible. Although its characteristic significantly reduces thermal stress, it is more susceptible to damage by external mechanical force. As a result, special handling precautions need to be observed during assembly using silicone encapsulated ALS (Ambient Light Sensor) products. Failure to comply might lead to damage and premature failure of the ALS (Ambient Light Sensor).

2. Storage

- 2.1. Do not open moisture proof bag before the products are ready to use.
- 2.2. Before opening the package, the ALS (Ambient Light Sensor) should be kept at 30°C or less and 60%RH or less.
- 2.3. The ALS (Ambient Light Sensor) should be used within a year.
- 2.4. After opening the package, the ALS (Ambient Light Sensor) should be kept at 30°C or less and 60%RH or less.
- 2.5. The ALS (Ambient Light Sensor) should be used within 24 hours after opening the package.
- 2.6. If the moisture adsorbent material has fabled away or the ALS (Ambient Light Sensor) have exceeded the storage time, baking treatment should be performed using the following conditions. Baking treatment: 65±5°C for 24 hours.

Technical Data Sheet

3. Soldering Condition

3.1. Pb-free solder temperature profile

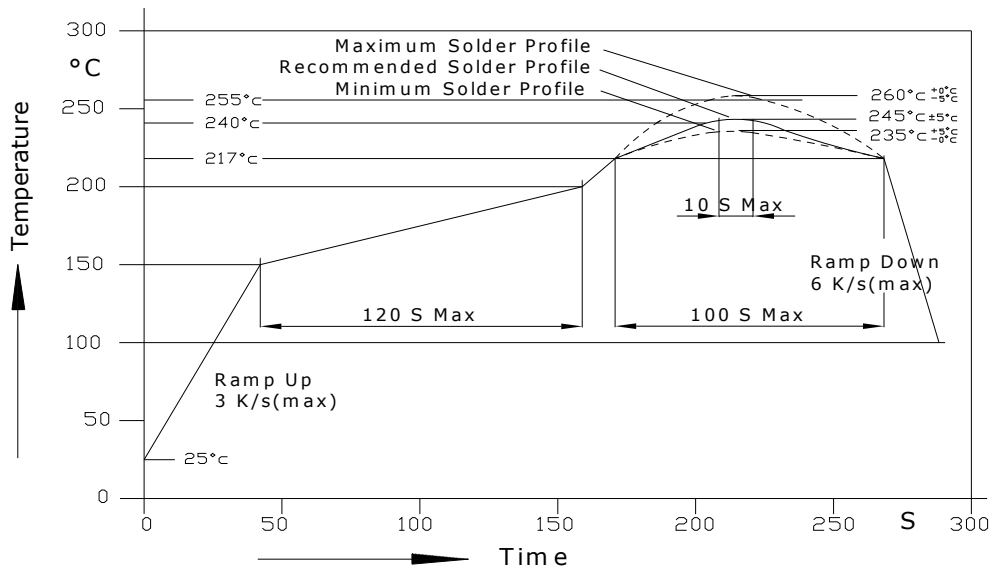

3.2. Reflow soldering should not be done more than two times.

3.3. When soldering, do not put stress on the ALS (Ambient Light Sensor) during heating.

3.4. After soldering, do not warp the circuit board.

3.5. Recommended soldering conditions:

Reflow soldering		Soldering iron	
Pre-heat	150~200°C	Temperature	300°C Max.
Pre-heat time	120 sec. Max.	Soldering time	3 sec. Max.
Peak temperature	260°C Max.		(one time only)
Soldering time	10 sec. Max.(Max. two times)		

3.6. Because different board designs use different number and types of devices, solder pastes, reflow ovens, and circuit boards, no single temperature profile works for all possible combinations.

AS-PDIC-L750-TR8

2.0x2.0mm, Ambient Light Sensor

With I²C Interface

The logo for LuckyLight, featuring the word "Lucky" in blue and "Light" in a lighter blue, with a red dot above the 'i' in "Light".

Technical Data Sheet

However, you can successfully mount your packages to the PCB by following the proper guidelines and PCB-specific characterization.

Terms and conditions for the usage of this document

1. The information included in this document reflects representative usage scenarios and is intended for technical reference only.
2. The part number, type, and specifications mentioned in this document are subject to future change and improvement without notice. Before production usage customer should refer to the latest datasheet for the updated specifications.
3. When using the products referenced in this document, please make sure the product is being operated within the environmental and electrical limits specified in the datasheet. If customer usage exceeds the specified limits, LuckyLight will not be responsible for any subsequent issues.
4. The information in this document applies to typical usage in consumer electronics applications. If customer's application has special reliability requirements or have life-threatening liabilities, such as automotive or medical usage, please consult with LuckyLight representative for further assistance.
5. The contents and information of this document may not be reproduced or re-transmitted without permission by LuckyLight.