

INDEX

Infrared Devices

IR Emitter.....	P226-233
Photodiode.....	P234-236
Phototransistor.....	P237-241
Infrared Receiver Module.....	P242-244

Part Number	Chip Material	Emitting Color	λ_p (nm) / x	λ_d (nm) / y	Lens Color	VF (V)		Power (mW/Sr)			Viewing Angle
						Typ.	Max.	IF=mA	Min.	Typ.	2 θ ½

3mm Round Standard Infrared Devices, T-1



304IRC2E-5AC	AlGaAs/GaAs	Infrared	940	---	Water Clear	1.20	1.50	20	6.0	12.0	15
--------------	-------------	----------	-----	-----	-------------	------	------	----	-----	------	----

3mm Round Standard Infrared Devices, T-1

304IRC4B-5AD	AlGaAs/GaAs	Infrared	940	---	Water Clear	1.20	1.50	20	6.0	10.0	30
304IRT4B-5AE	AlGaAs/GaAs	Infrared	940	---	Blue Transparent	1.20	1.50		5.0	8.0	40
304HIRC4B-5CD	AlGaAs/AlGaAs	Infrared	880	---	Water Clear	1.30	1.60		8.0	10.0	30
304HIRT4B-5CE	AlGaAs/AlGaAs	Infrared	880	---	Blue Transparent	1.30	1.60		6.0	12.0	45
304SIRC4B-5AD	AlGaAs/AlGaAs	Infrared	850	---	Water Clear	1.40	1.60		6.0	12.0	30

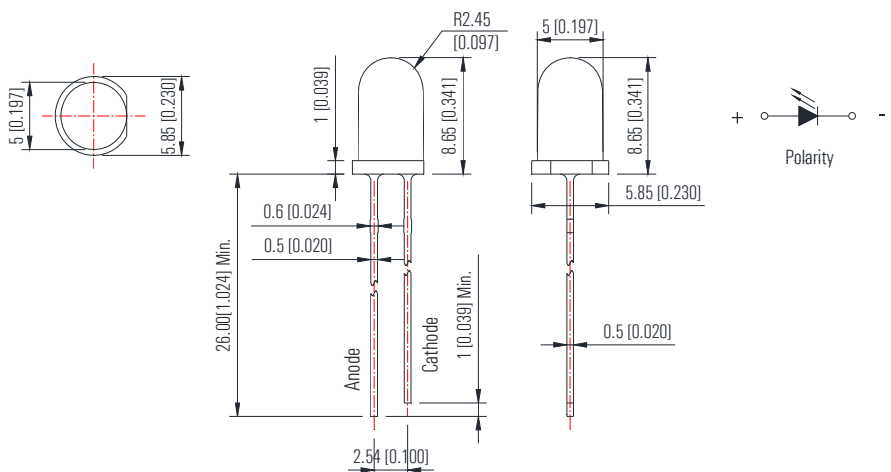

Part Number	Chip Material	Emitting Color	λ_p (nm) / x	λ_d (nm) / y	Lens Color	VF (V)		Power (mW/Sr)			Viewing Angle
						Typ.	Max.	IF=mA	Min.	Typ.	2 θ 1/2

5mm Round Standard Infrared Devices, T-1 3/4

503IRC2E-5AC	AlGaAs/GaAs	Infrared	940	---	Water Clear	1.20	1.50	20	7.8	12.0	15
503IRC2E-5AE	AlGaAs/GaAs	Infrared	940	---	Water Clear	1.20	1.50		6.0	12.0	45
503IRT2E-5AC	AlGaAs/GaAs	Infrared	940	---	Blue Transparent	1.20	1.50		7.0	10.0	15
503HIRC2E-5CC	AlGaAs/AlGaAs	Infrared	880	---	Water Clear	1.30	1.60		7.8	12.0	
503HIRC2E-5CE	AlGaAs/AlGaAs	Infrared	880	---	Water Clear	1.30	1.60		6.5	13.0	45
503HIRT2E-5CC	AlGaAs/AlGaAs	Infrared	880	---	Blue Transparent	1.30	1.60		7.0	10.0	15
503SIRC2E-5AC	AlGaAs/AlGaAs	Infrared	850	---	Water Clear	1.40	1.60		7.8	15.0	
503SIRC2E-5AE	AlGaAs/AlGaAs	Infrared	850	---	Water Clear	1.40	1.60		8.0	15.0	45
503KIRC2E-4CE	AlGaAs/AlGaAs	Infrared	830	---	Water Clear	1.40	1.60		6.0	13.0	

5mm Round Standard Infrared Devices, T-1 3/4

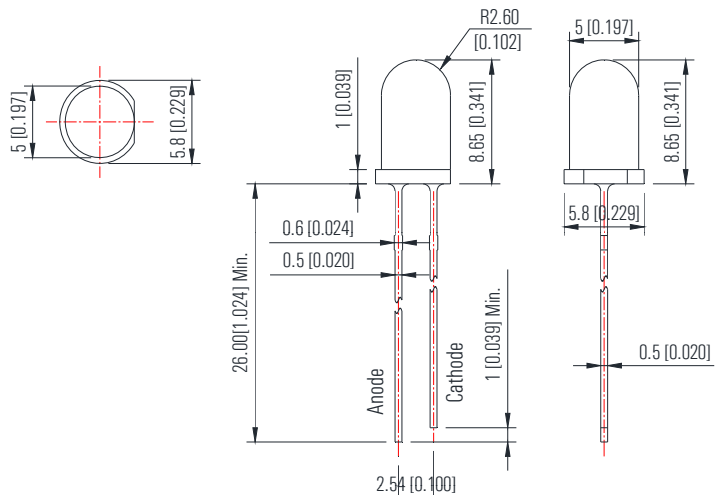
503IRC2V-5AD	AlGaAs/GaAs	Infrared	940	---	Water Clear	1.20	1.50	20	7.8	12.0	30
503IRT2V-5AD	AlGaAs/GaAs	Infrared	940	---	Blue Transparent	1.20	1.50		6.0	10.0	
503HIRC2V-5CD	AlGaAs/AlGaAs	Infrared	880	---	Water Clear	1.30	1.60		7.0	13.5	
503HIRT2V-5CD	AlGaAs/AlGaAs	Infrared	880	---	Blue Transparent	1.30	1.60		6.5	13.0	
503SIRC2V-5AD	AlGaAs/AlGaAs	Infrared	850	---	Water Clear	1.40	1.60		7.8	15.0	
503KIRC2V-4CD	AlGaAs/AlGaAs	Infrared	830	---	Water Clear	1.40	1.60		7.8	15.0	

Part Number	Chip Material	Emitting Color	λ_p (nm) / x	λ_d (nm) / y	Lens Color	VF (V)		Power (mW/Sr)			Viewing Angle
						Typ.	Max.	IF=mA	Min.	Typ.	2 θ 1/2

5mm Round Infrared Devices, T-1 3/4

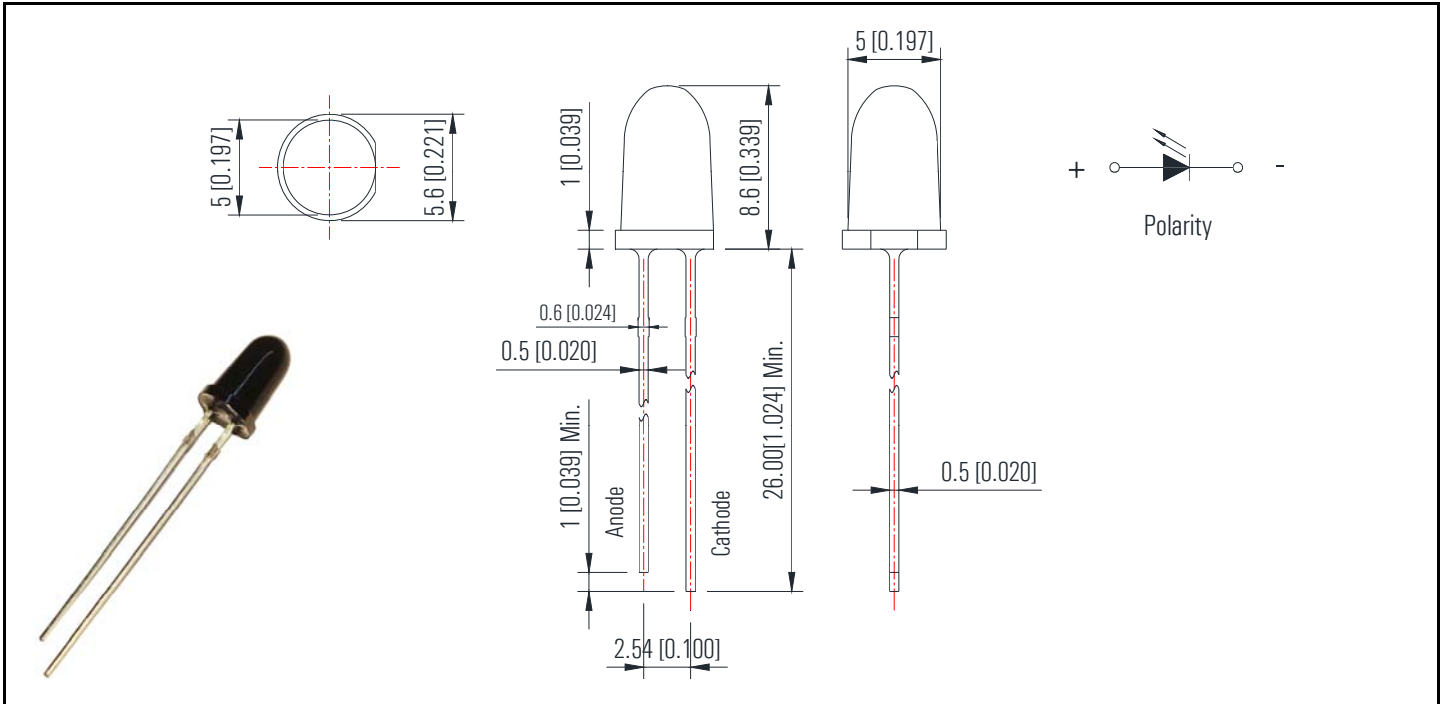

583SIRD2C-5CA-R	AlGaAs/GaAs	Infrared	850	---	Black	1.40	1.60	50	45.0	90.0	8
						1.60	1.80	100	150.0	350.0	

5mm Round Infrared Devices, T-1 3/4

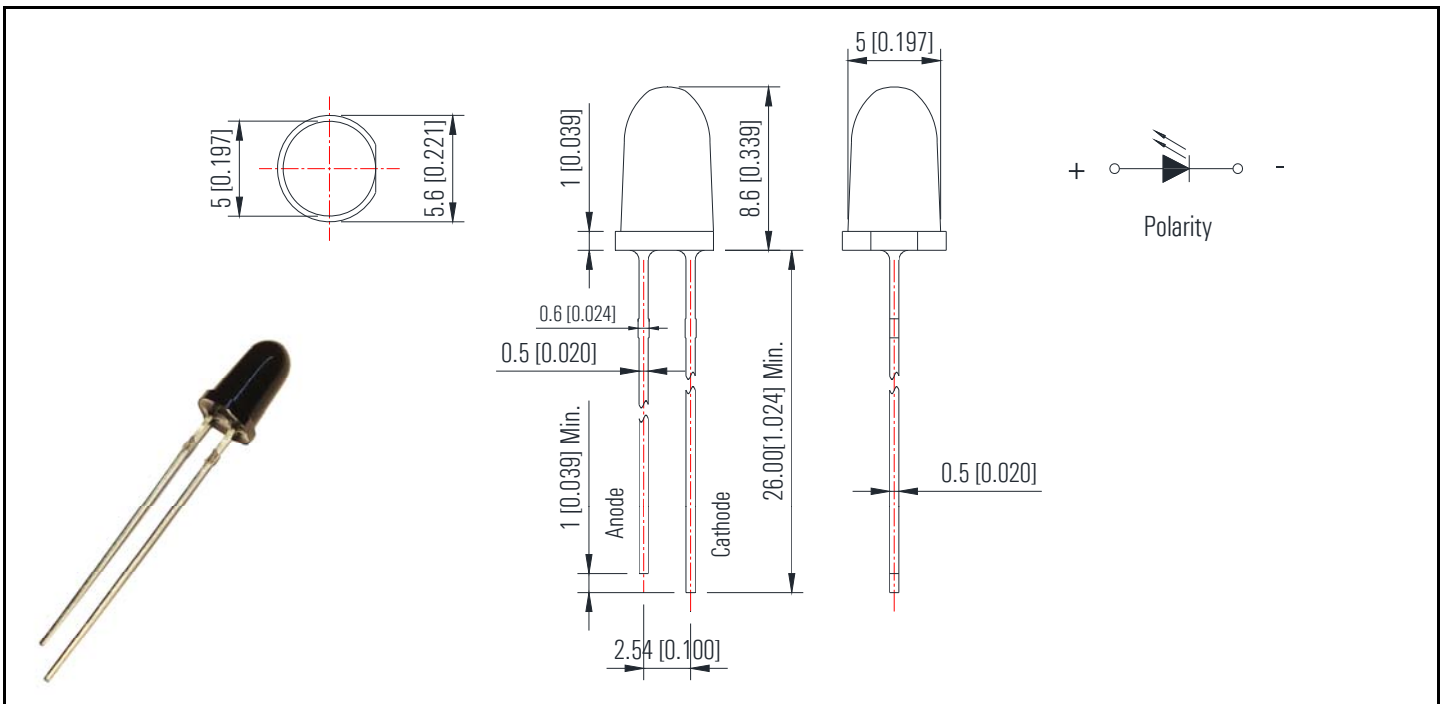

583SIRD2C-CRA	AlGaAs/GaAs	Infrared	850	---	Black	1.40	1.60	50	80.0	120.0	8
						1.60	1.70	100	180.0	450.0	

Part Number	Chip Material	Emitting Color	λ_p (nm) / x	λ_d (nm) / y	Lens Color	VF (V)		Power (mW/Sr)			Viewing Angle
						Typ.	Max.	IF=mA	Min.	Typ.	2θ 1/2

5mm Round Infrared Devices, T-1 3/4

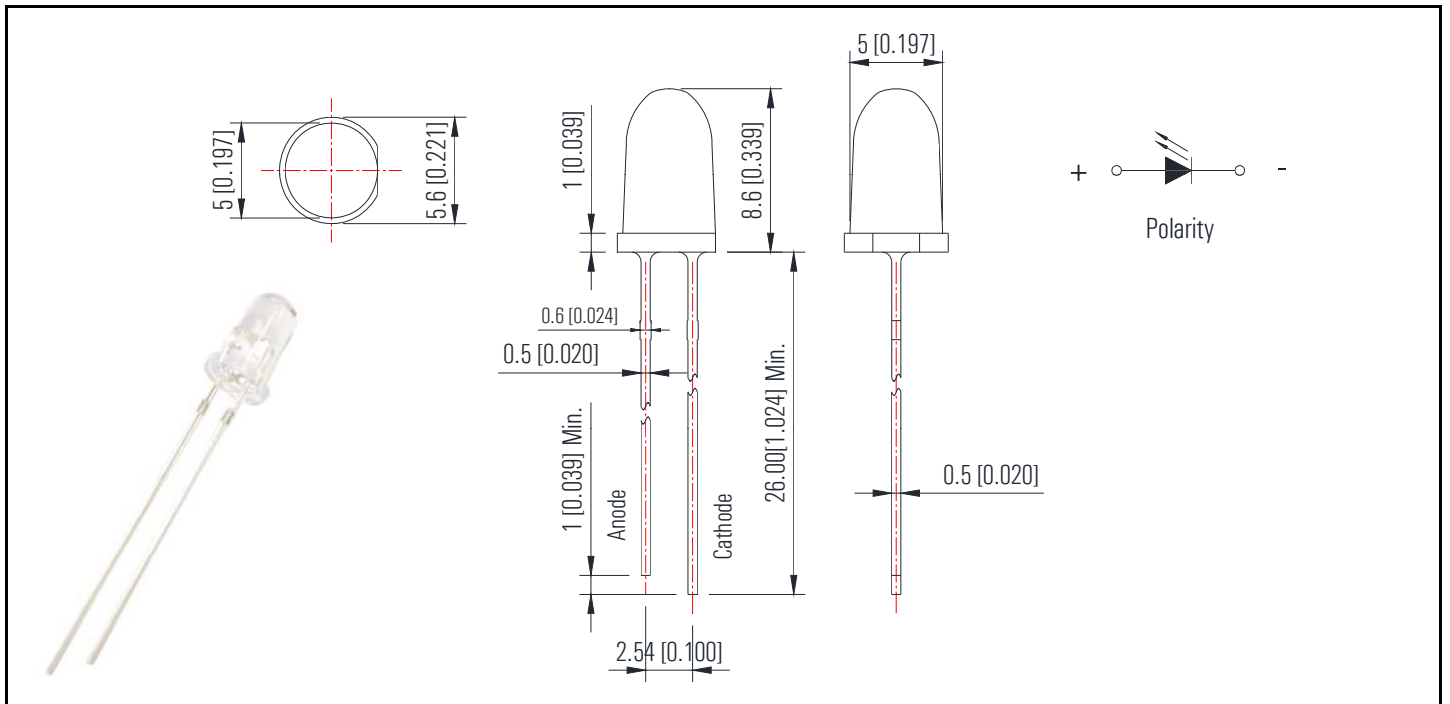

503SIRC5R-CRA-R	AlGaAs/GaAs	Infrared	850	---	Water Clear	1.40	1.60	50	380.0	500.0	6
						1.60	1.80	100	860.0	1100.0	

4.45mm×5.70mm Side View Infrared Devices

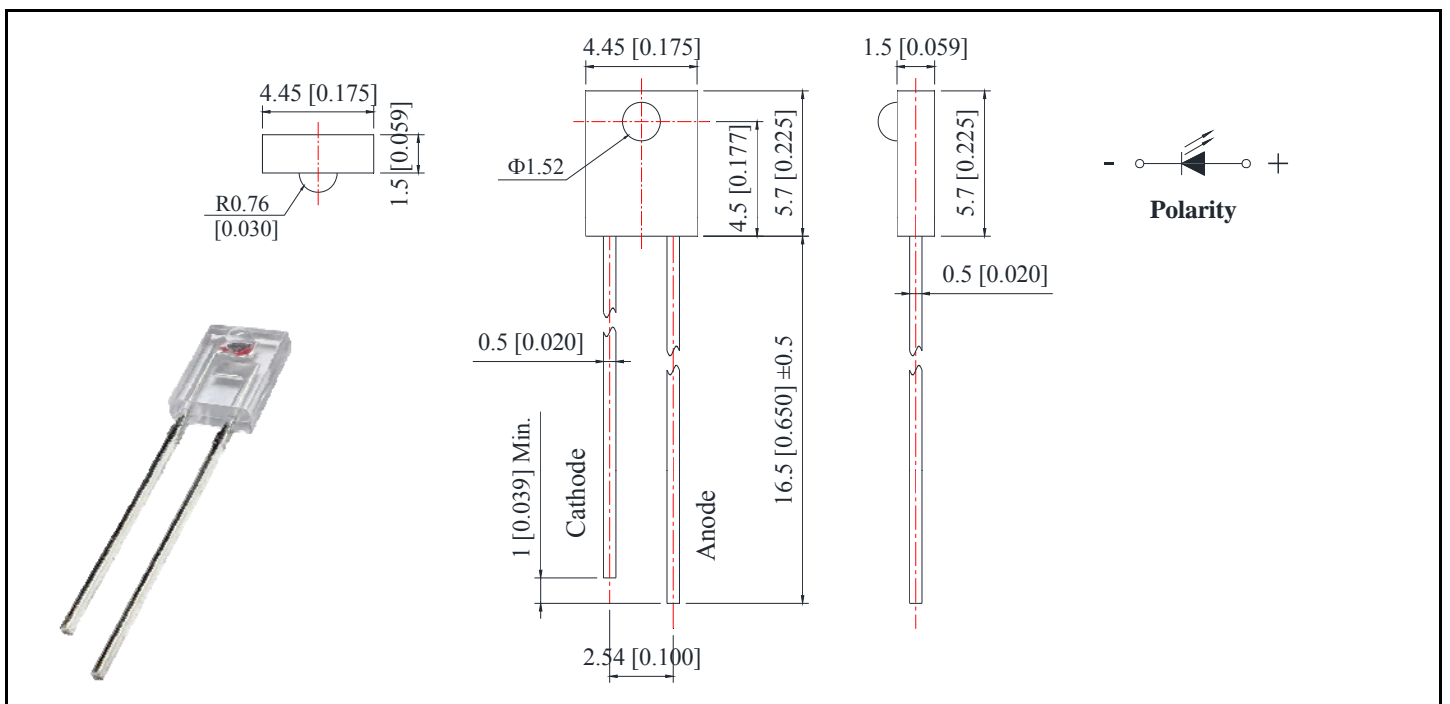

IR23C1	AlGaAs/GaAs	Infrared	940	---	Water Clear	1.20	1.50	4	0.36	0.54	30
--------	-------------	----------	-----	-----	-------------	------	------	---	------	------	----

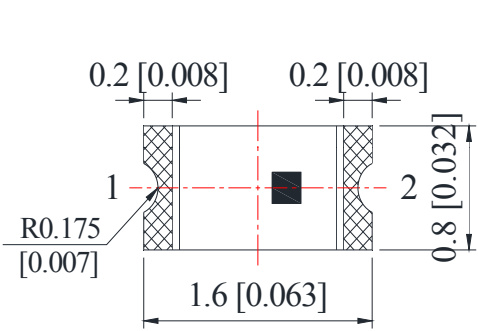
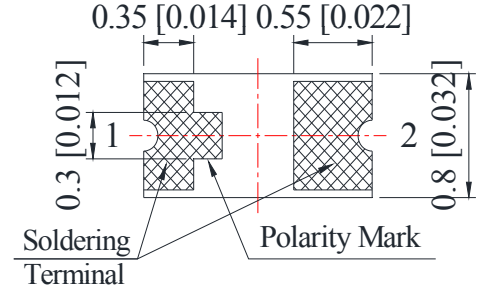
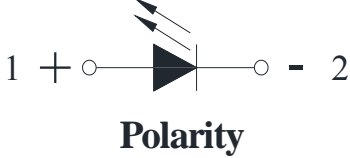

Part Number	Chip Material	Emitting Color	λ_p (nm) / x	λ_d (nm) / y	Lens Color	VF (V)		Power (mW/Sr)			Viewing Angle
						Typ.	Max.	IF=mA	Min.	Typ.	2 θ 1/2

1.60mm×0.80mm×0.80mm (0603) SMD Infrared Devices

S190IRC-2A	AlGaAs/GaAs	Infrared	940	---	Water Clear	1.20	1.50	20	0.20	0.35	140
------------	-------------	----------	-----	-----	-------------	------	------	----	------	------	-----

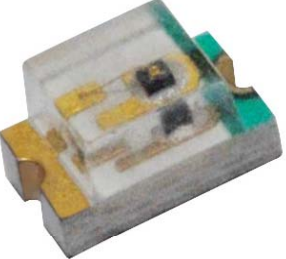
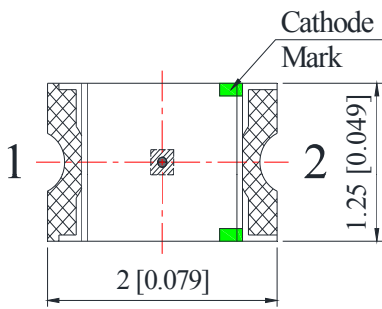
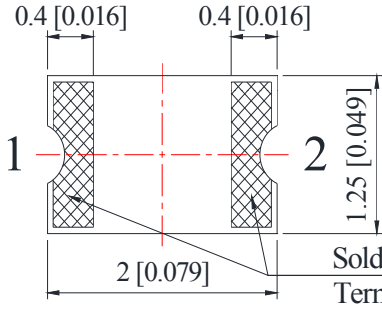

2.00mm×1.25mm×1.10mm (0805) SMD Infrared Devices

S170IRC-2A	AlGaAs/GaAs	Infrared	940	---	Water Clear	1.20	1.50	20	0.20	0.35	140
------------	-------------	----------	-----	-----	-------------	------	------	----	------	------	-----

Part Number	Chip Material	Emitting Color	λ_p (nm) / x	λ_d (nm) / y	Lens Color	VF (V)		Power (mW/Sr)			Viewing Angle
						Typ.	Max.	IF=mA	Min.	Typ.	2 θ 1/2

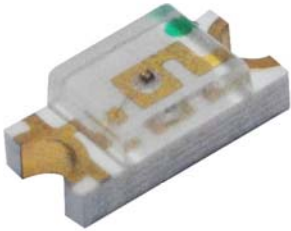
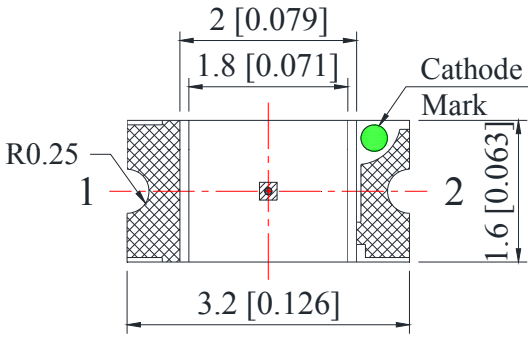
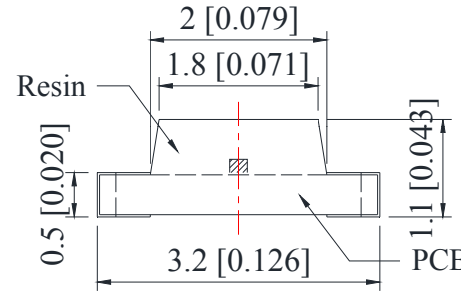
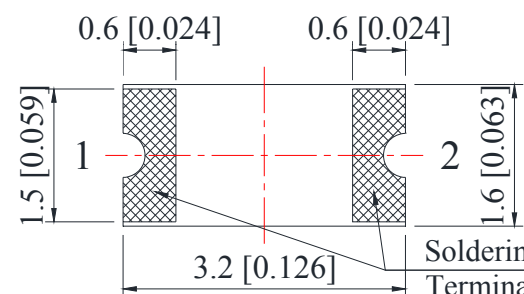

3.20mm×1.60mm×1.10mm (1206) SMD Infrared Devices

Polarity

S150IRC-2A	AlGaAs/GaAs	Infrared	940	---	Water Clear	1.20	1.50	20	0.20	0.35	140
------------	-------------	----------	-----	-----	-------------	------	------	----	------	------	-----

2.15mm×2.40mm×2.75mm (1.80mm Round) Subminiature Axial Infrared Devices

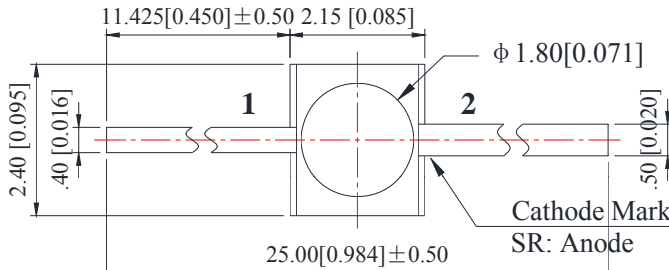
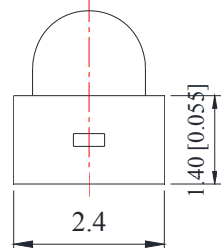
Polarity

AR180IRC-2A	AlGaAs/GaAs	Infrared	940	---	Water Clear	1.20	1.50	20	3.00	6.00	25
-------------	-------------	----------	-----	-----	-------------	------	------	----	------	------	----

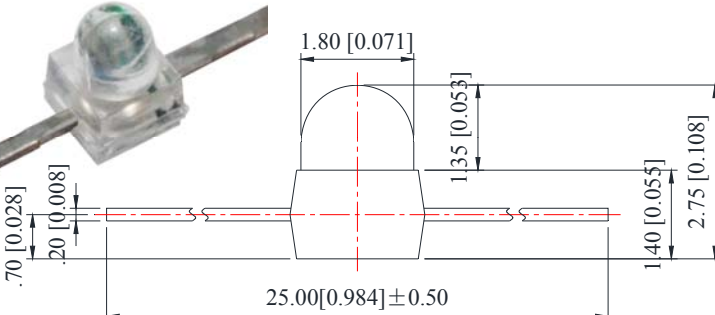
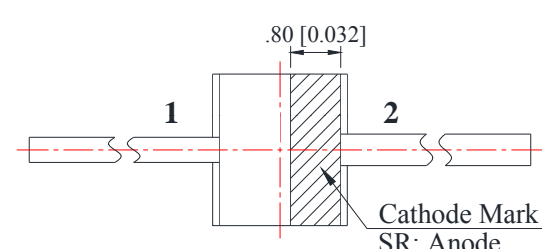
Part Number	Chip Material	Emitting Color	λ_p (nm) / x	λ_d (nm) / y	Lens Color	VF (V)		Power (mW/Sr)			Viewing Angle
						Typ.	Max.	IF=mA	Min.	Typ.	2 θ 1/2

2.15mm×2.40mm×2.75mm (1.80mm Round) Subminiature Axial Infrared Devices

Technical drawing of AR180IRC-2A/TR2 device showing top, side, and cross-sectional views with dimensions and a polarity diagram.

Dimensions (mm):

- Top view: 2.15 [0.085] (width), 4.65 [0.183] ± 0.50 (length), ϕ 1.80 [0.071] (circle diameter), 2.40 [0.095] (total height), 0.40 [0.016] (lead height), 0.50 [0.020] (lead length).
- Side view: 1.40 [0.055] (height), 2.4 (width).
- Bottom view: 1.80 [0.071] (width), 1.25 [0.049] (lead width), 1.35 [0.053] (lead height), 1.40 [0.055] (height), 2.75 [0.108] (total height), 0.75 [0.030] (lead height), 0.20 [0.008] (lead width), 3.21 [0.127] ± 0.50 (width), 4.65 [0.183] ± 0.50 (length).
- Cross-section: 0.80 [0.032] (width), Cathode Mark SR: Anode.

Polarity diagram: 1 + (Anode) - (Cathode) 2

AR180IRC-2A/TR2	AlGaAs/GaAs	Infrared	940	---	Water Clear	1.20	1.50	20	3.00	6.00	25
-----------------	-------------	----------	-----	-----	-------------	------	------	----	------	------	----

3.50mm×2.80mm×2.40mm PLCC-2 Narrow Angle Mid Power Infrared Devices

Technical drawing of R2835SIR1C-2B device showing top, side, and cross-sectional views with dimensions and a polarity diagram.

Dimensions (mm):



- Top view: 3.2 [0.126] (width), ϕ 2.20 [0.087] (circle diameter), 3.5 [0.138] (length), 1.9 [0.075] (lead height), 2.8 [0.110] (height).
- Side view: 2.2 [0.087] (width), 1.05 [0.041] (lead height), 2.4 [0.095] (height).
- Bottom view: 0.45 [0.018] (width), 1.9 [0.075] (lead height), 1.2 [0.047] (lead width), 0.85 [0.073] (width), Soldering Terminal.

Polarity diagram: 1 - (Cathode) + (Anode) 2

R2835SIR1C-2B	AlGaAs/GaAs	Infrared	850	---	Water Clear	1.40	1.60	100	100.0	140.0	30
---------------	-------------	----------	-----	-----	-------------	------	------	-----	-------	-------	----

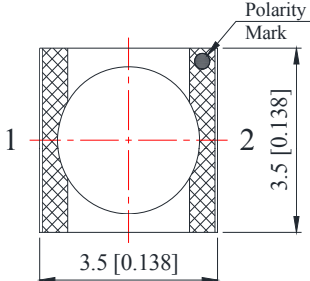
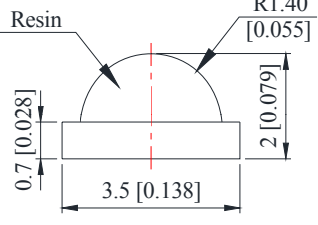
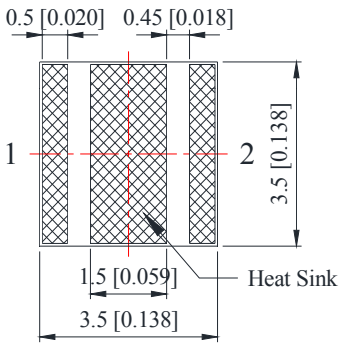

Part Number	Chip Material	Emitting Color	λ_p (nm) / x	λ_d (nm) / y	Lens Color	VF (V)		Power (mW/Sr)			Viewing Angle
						Typ.	Max.	IF=mA	Min.	Typ.	2 θ ½

1W, 3W High Power Infrared Devices

C3535SIRC-2B	AlGaAs/GaAs	Infrared	850	---	Water Clear	1.80	2.00	350	130.0	160.0	120
								700	300.0	330.0	

1W, 3W Narrow Angle High Power Infrared Devices

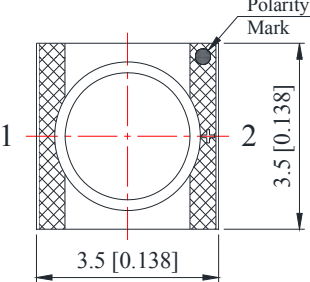
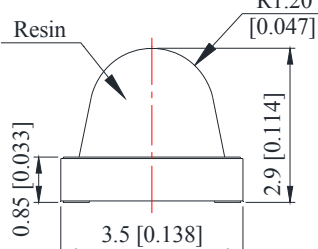
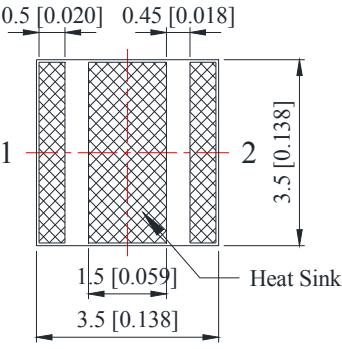





C3535SIR2C-3B	AlGaAs/GaAs	Infrared	850	---	Water Clear	1.80	2.00	350	130.0	160.0	60
								700	300.0	330.0	
								1000	400.0	430.0	

- All dimensions are in millimeters (inches).
- Tolerance is $\pm 0.10\text{mm}$ (.004") unless otherwise noted.
- Specifications are subject to change without notice.

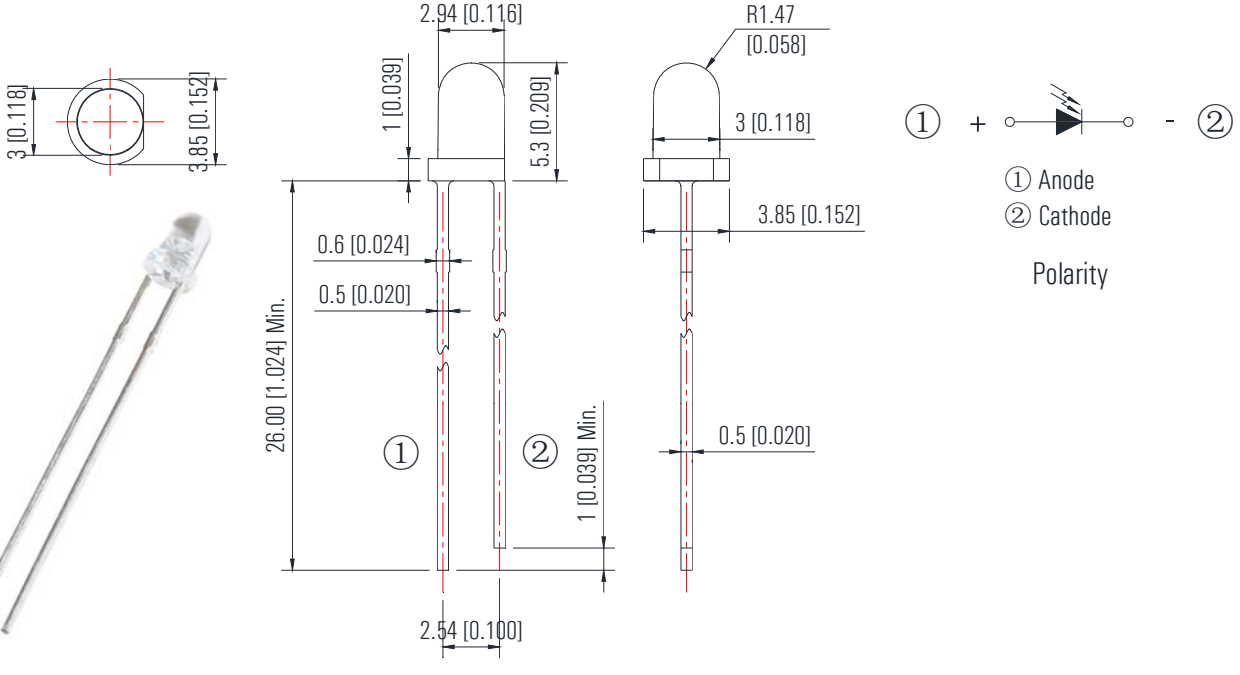
Part Number	Chip Material	Lens Color	Rise & Fall Time	V _{(BR)R} Min. (V)	I _L		I _D	
					Ee=mW/cm ²	Typ. (μA)	Ee=mW/cm ²	Max. (nA)

3mm Silicon PIN Photodiode, T-1

Technical drawing showing dimensions and polarity for the 304PDC2E-3A photodiode. Dimensions are provided in millimeters and inches in brackets. The drawing includes a top view, a side view, and a cross-sectional view. The top view shows a diameter of 3.0 mm [0.118] and a mounting hole diameter of 3.85 mm [0.152]. The side view shows a total height of 26.00 mm [1.024] Min. and a lens diameter of 2.94 mm [0.116]. The cross-sectional view shows a lens radius of R1.47 [0.058], a lens thickness of 1.0 mm [0.039], and a mounting hole diameter of 3.85 mm [0.152]. The anode (1) and cathode (2) are indicated. The polarity is shown as ① + and ② -.

304PDC2E-3A	Silicon	Water Clear	45 / 45	32	20	35	5	30
-------------	---------	-------------	---------	----	----	----	---	----

3mm Silicon PIN Photodiode, T-1

Technical drawing showing dimensions and polarity for the 304PDD2E-3A photodiode. Dimensions are provided in millimeters and inches in brackets. The drawing includes a top view, a side view, and a cross-sectional view. The top view shows a diameter of 3.0 mm [0.118] and a mounting hole diameter of 3.85 mm [0.152]. The side view shows a total height of 26.00 mm [1.024] Min. and a lens diameter of 2.94 mm [0.116]. The cross-sectional view shows a lens radius of R1.47 [0.058], a lens thickness of 1.0 mm [0.039], and a mounting hole diameter of 3.85 mm [0.152]. The anode (1) and cathode (2) are indicated. The polarity is shown as ① + and ② -.

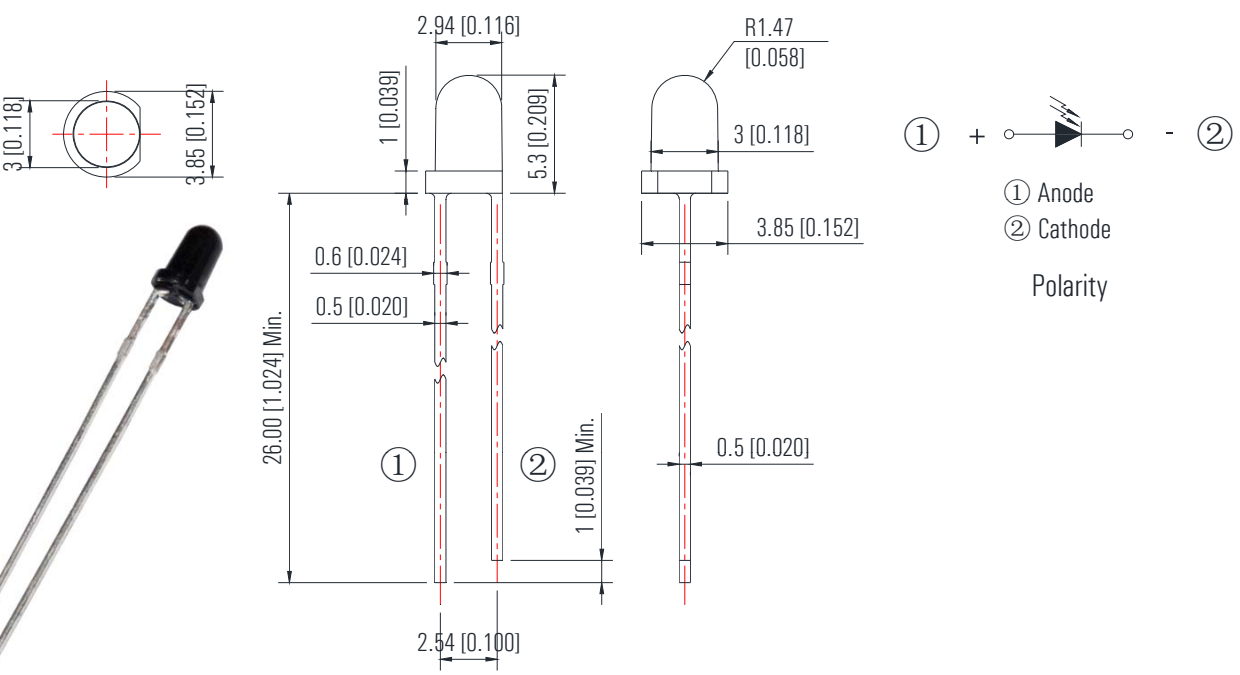
304PDD2E-3A	Silicon	Black	45 / 45	32	20	35	5	30
-------------	---------	-------	---------	----	----	----	---	----

Part Number	Chip Material	Lens Color	Rise & Fall Time	V _{(BR)R} Min. (V)	I _L		I _D	
					Ee=mW/cm ²	Typ. (μA)	Ee=mW/cm ²	Max. (nA)

5mm Silicon PIN Photodiode, T-1 3/4

504PDC2B-3A	Silicon	Water Clear	45 / 45	32	20	35	5	30
-------------	---------	-------------	---------	----	----	----	---	----

5mm Silicon PIN Photodiode, T-1 3/4

504PDD2B-3A	Silicon	Black	45 / 45	32	20	35	5	30
-------------	---------	-------	---------	----	----	----	---	----

Part Number	Chip Material	Lens Color	Rise & Fall Time	$V_{(BR)R}$ Min. (V)	IL		Id	
					Ee=mW/cm ²	Typ. (μA)	Ee=mW/cm ²	Max. (nA)

5mm Silicon PIN Photodiode, T-1 3/4

503PDD1A-5A-R	Silicon	Black	30 / 30	35	20	35	5	10
---------------	---------	-------	---------	----	----	----	---	----

5mm Silicon PIN Photodiode, T-1 3/4

503PDD1A-5C-R	Silicon	Black	30 / 30	35	20	30	5	10
---------------	---------	-------	---------	----	----	----	---	----

1. All dimensions are in millimeters (inches).
2. Tolerance is ±0.25mm (.010") unless otherwise noted.
3. Specifications are subject to change without notice.

Part Number	Chip Material	Lens Color	Rise & Fall Time (μ s)	BV_{CEO} Min. (V)	$V_{CE(SAT)}$		$I_C(ON)$	
					$E_e=mW/cm^2$	Max. (V)	$E_e=mW/cm^2$	Min. (mA)

3mm Round Standard Phototransistor, T-1

304PTC4B-1A	Silicon	Water Clear	15 / 15	30	1.00	0.40	1.00	0.70

3mm Round Standard Phototransistor, T-1

304PTD4B-1A	Silicon	Black	15 / 15	30	1.00	0.40	1.00	0.70

Part Number	Chip Material	Lens Color	Rise & Fall Time (μ s)	BV_{CEO} Min. (V)	V_{CE} (SAT)		I_C (ON)	
					$E_e = mW/cm^2$	Max. (V)	$E_e = mW/cm^2$	Min. (mA)

5mm Round Standard Phototransistor, T-1 3/4

503PTC2E-1A	Silicon	Water Clear	15 / 15	30	1.00	0.40	1.00	0.70
-------------	---------	-------------	---------	----	------	------	------	------

5mm Round Standard Phototransistor, T-1 3/4

503PTD2E-1A	Silicon	Black	15 / 15	30	1.00	0.40	1.00	0.70
-------------	---------	-------	---------	----	------	------	------	------

Part Number	Chip Material	Lens Color	Rise & Fall Time (μ)	BV _{CEO} Min. (V)	V _{CE} (SAT)		I _C (ON)	
					Ee=mW/cm ²	Max. (V)	Ee=mW/cm ²	Min. (mA)

4.45mm×5.70mm Side View Phototransistor

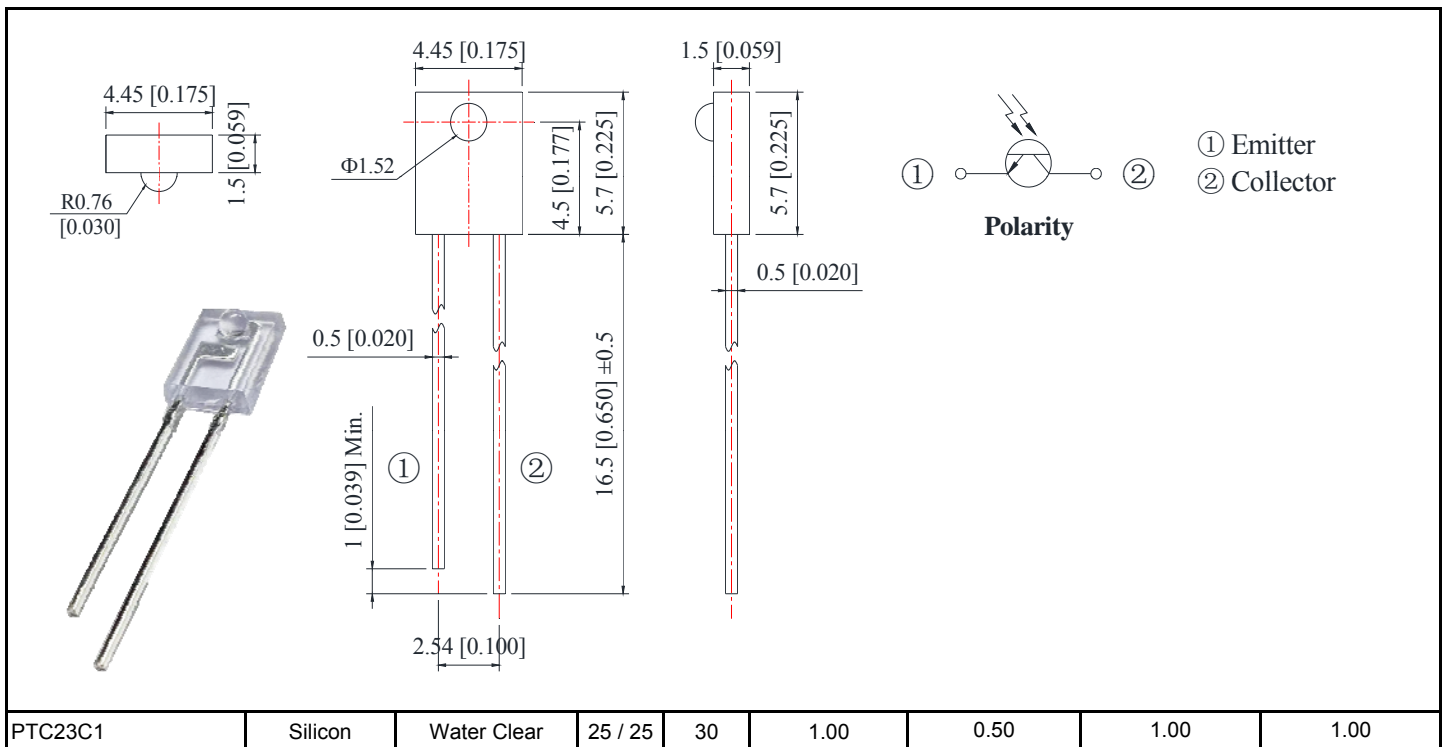

3.20mm×1.60mm×1.10mm (1206) Chip Phototransistor

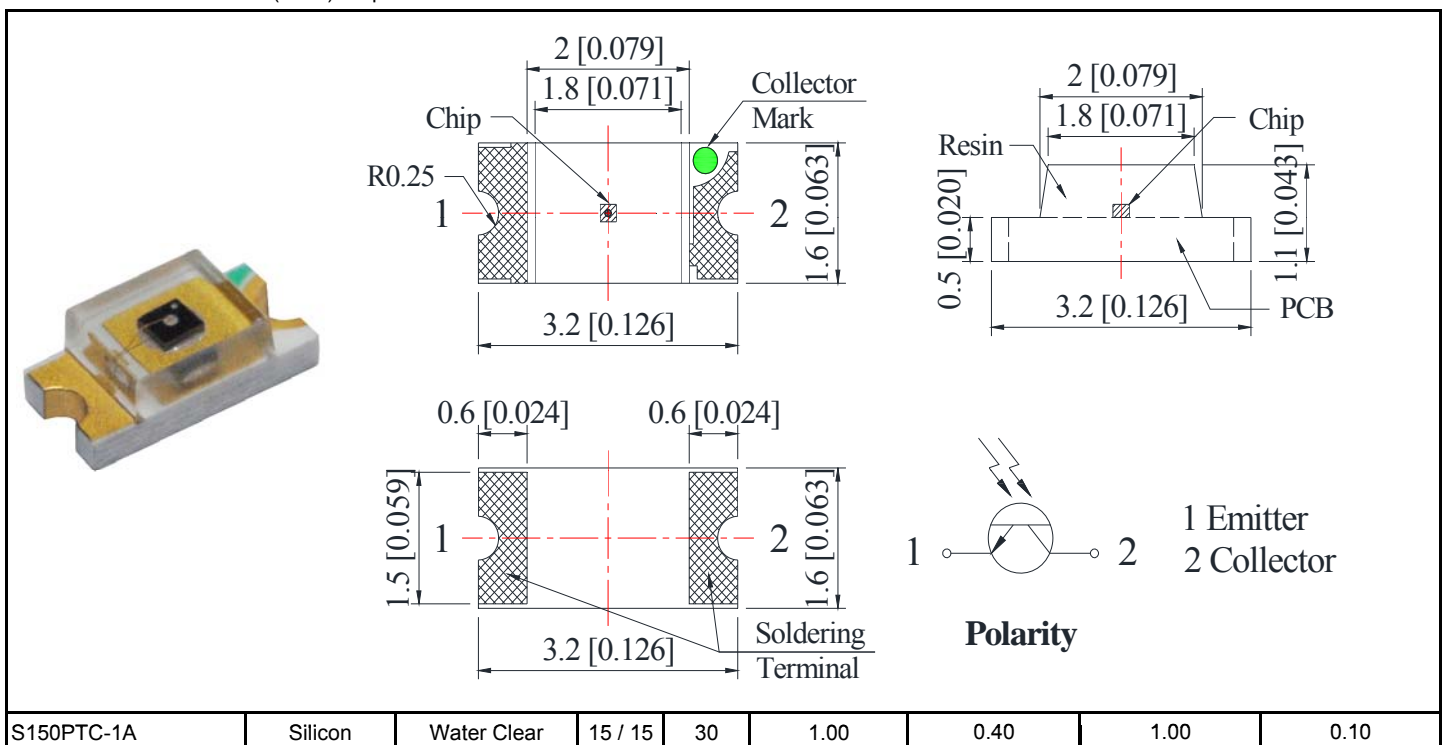

Part Number	Chip Material	Lens Color	Rise & Fall Time (μ)	BV_{CEO} Min. (V)	V_{CE} (SAT)		I_C (ON)	
					$E_e=mW/cm^2$	Max. (V)	$E_e=mW/cm^2$	Min. (mA)

3.20mm×1.60mm×1.10mm (1206) Chip Phototransistor

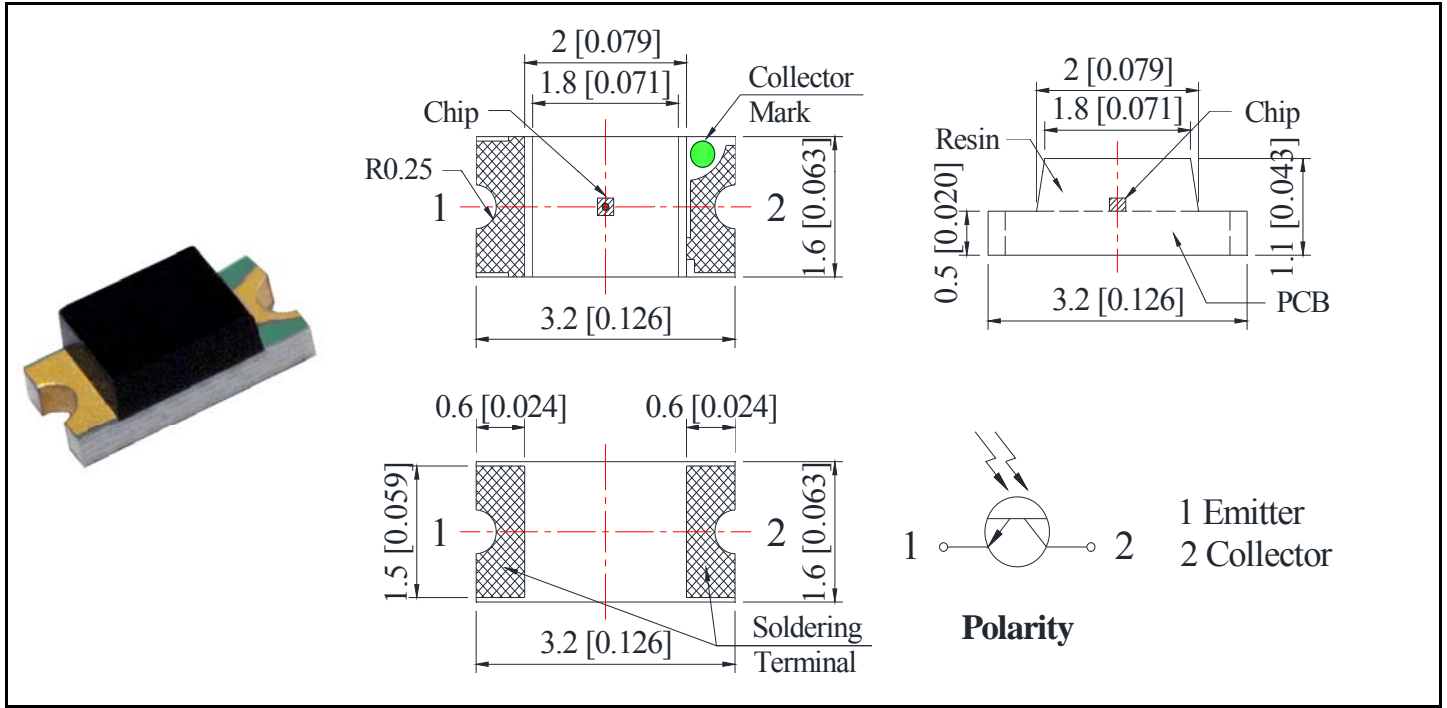

S150PTD-1A	Silicon	Black	15 / 15	30	1.00	0.40	1.00	0.10
------------	---------	-------	---------	----	------	------	------	------

2.15mm×2.40mm×2.75mm (Φ 1.80mm Round) Subminiature Axial Chip Phototransistor

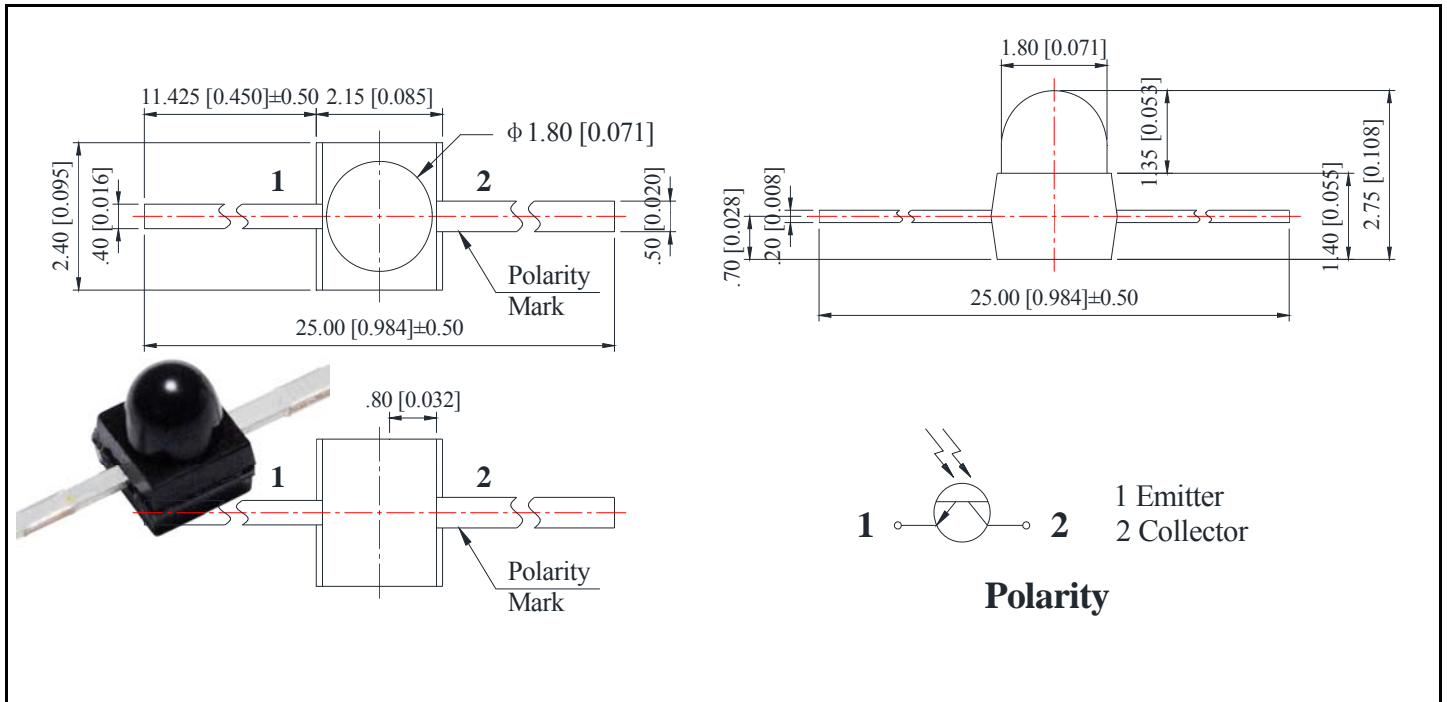

AR180PTD-1A	Silicon	Black	15 / 15	30	1.00	0.30	1.00	1.00
-------------	---------	-------	---------	----	------	------	------	------

Part Number	Chip Material	Lens Color	Rise & Fall Time (μ)	BV _{CEO} Min. (V)	V _{CE} (SAT)		I _C (ON)	
					Ee=mW/cm ²	Max. (V)	Ee=mW/cm ²	Min. (mA)

2.15mm×2.40mm×2.75mm (Φ1.80mm Round) Subminiature Axial Chip Phototransistor

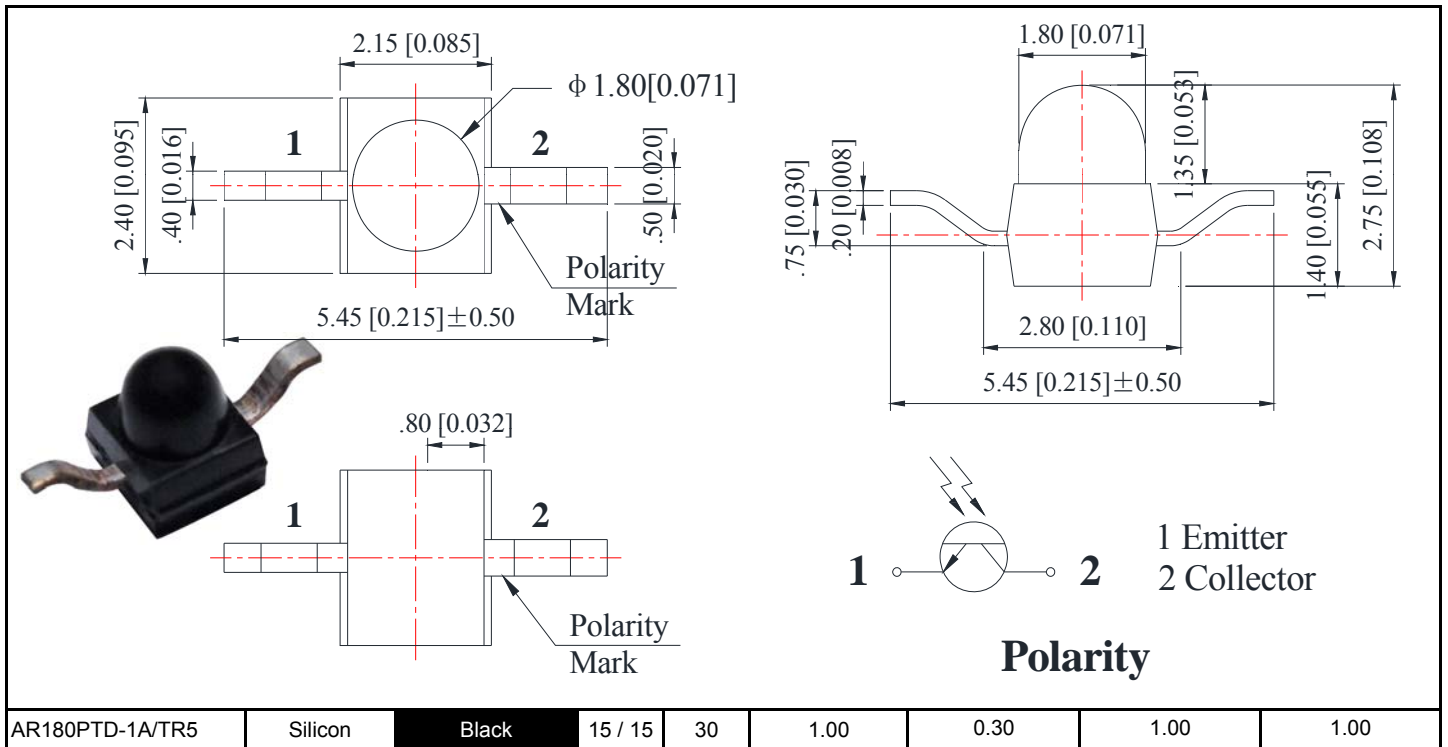

1. All dimensions are in millimeters (inches).
2. Tolerance is ± 0.25 mm (.010") unless otherwise noted.
3. Specifications are subject to change without notice.

Part Number	B.P.F.	Supply Voltage Typ. (V)	Supply Current Typ. (mA)	Transmission Distance Min. (m)	Angle θ_h (°)
	Center Frequency				

Infrared Remote Control Receiver Module (IRM)

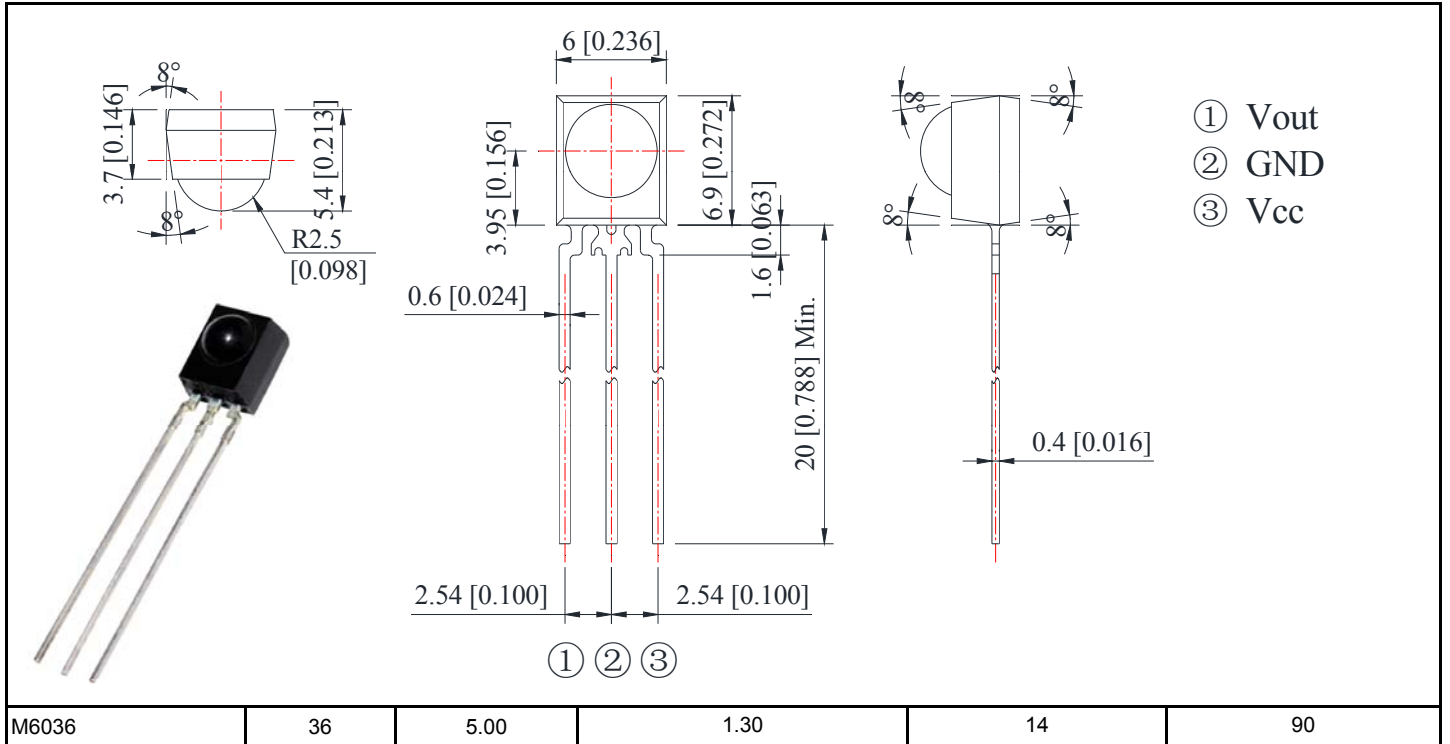

Infrared Remote Control Receiver Module (IRM)

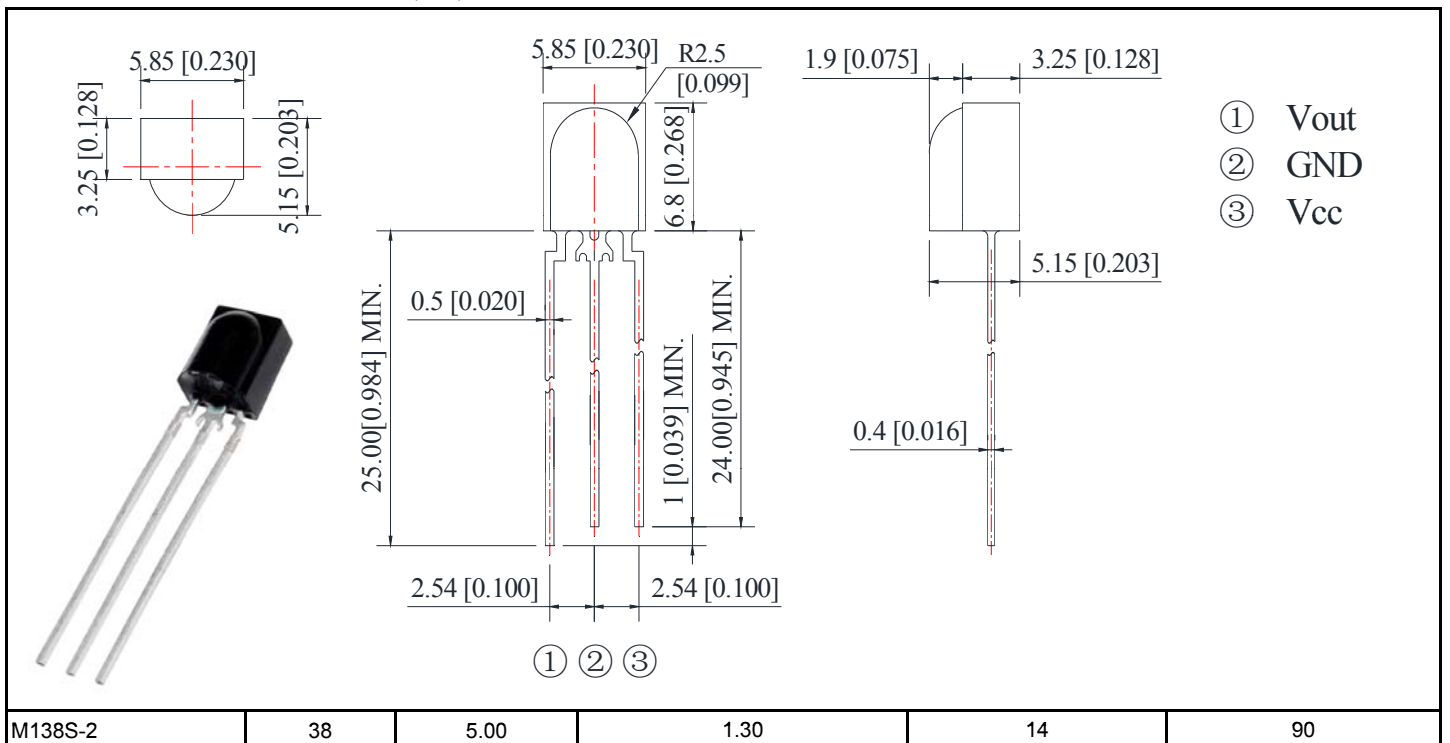

Part Number	B.P.F.	Supply Voltage Typ. (V)	Supply Current Typ. (mA)	Transmission Distance Min. (m)	Angle θ_h (°)
	Center Frequency				

Infrared Remote Control Receiver Module (IRM)

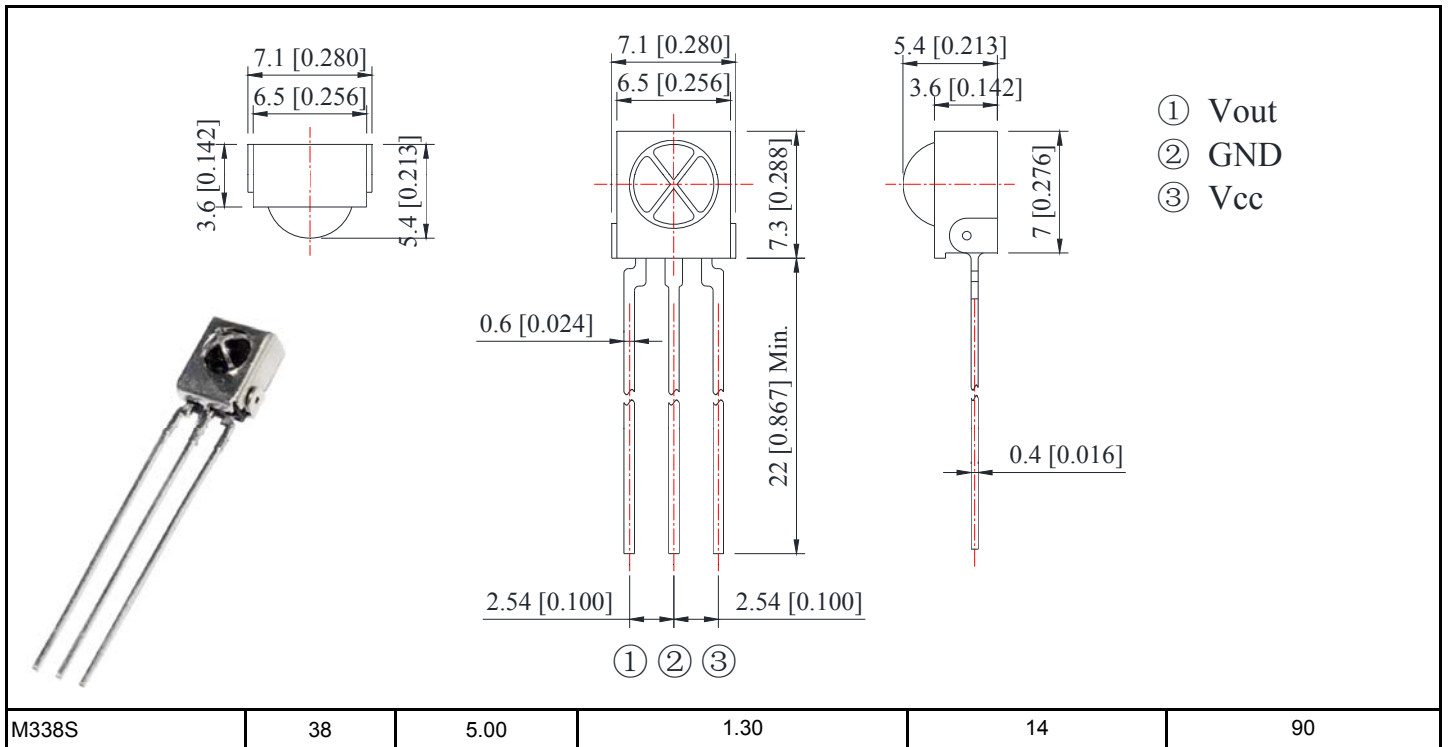

Infrared Remote Control Receiver Module (IRM)

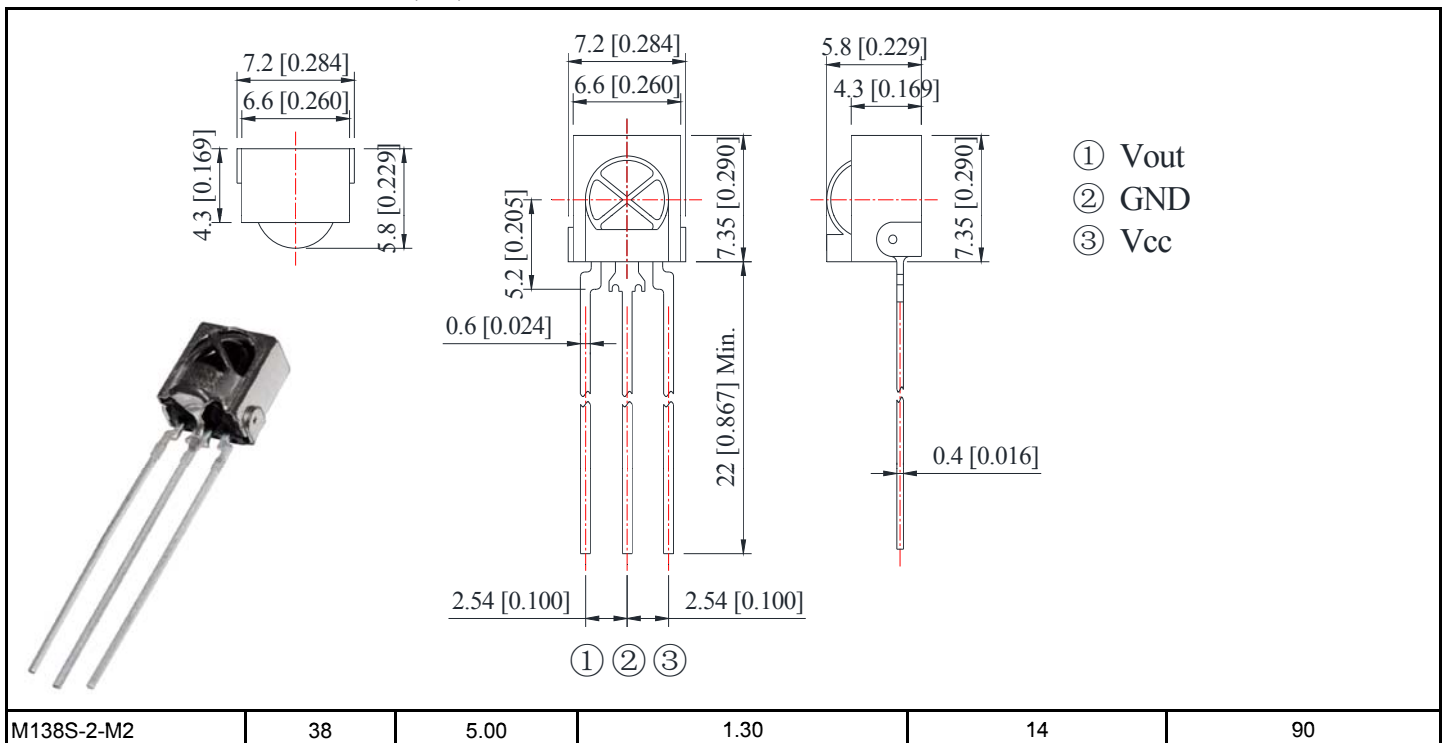

Part Number	B.P.F.	Supply Voltage Typ. (V)	Supply Current Typ. (mA)	Transmission Distance Min. (m)	Angle θ_h (°)
	Center Frequency				

Infrared Remote Control Receiver Module (IRM)

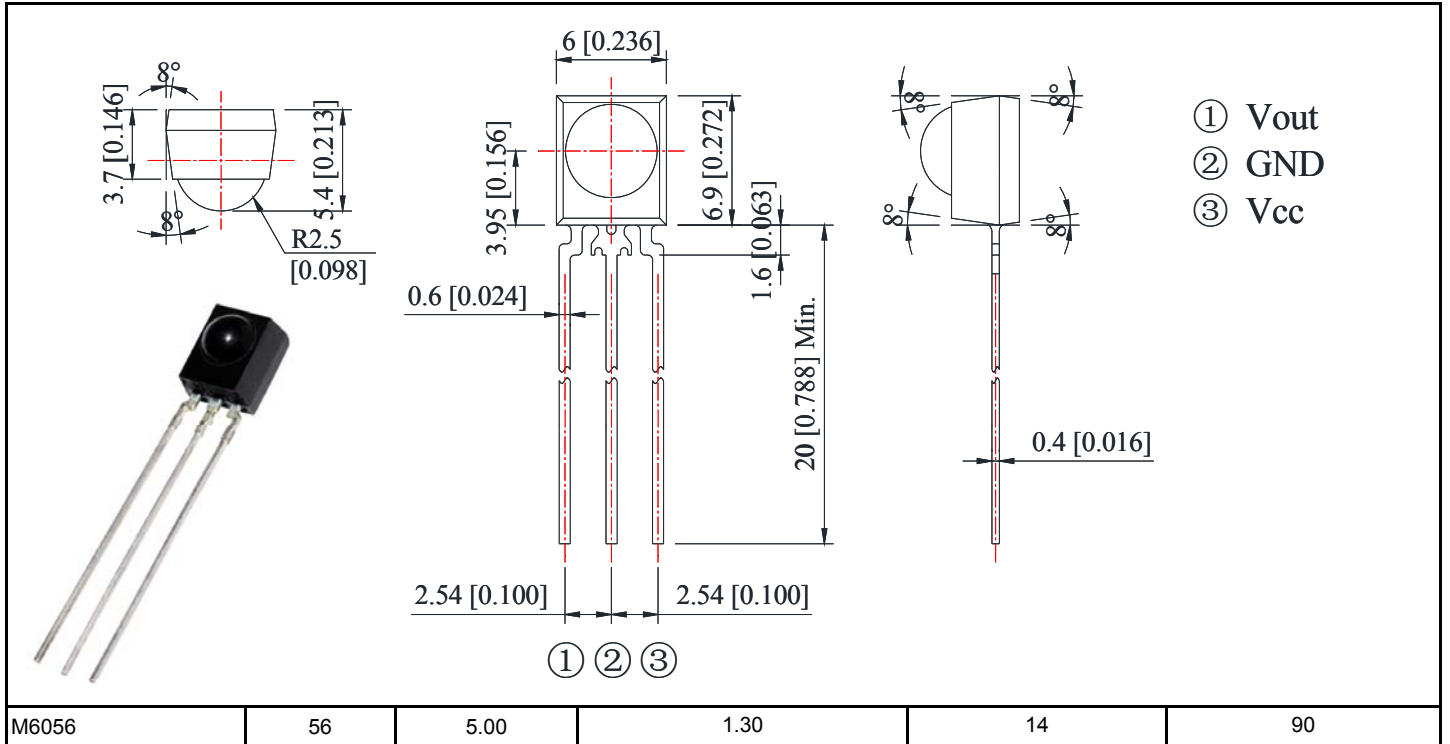

1. All dimensions are in millimeters (inches).
 2. Tolerance is $\pm 0.25\text{mm}$ (.010") unless otherwise noted.
 3. Specifications are subject to change without notice.